

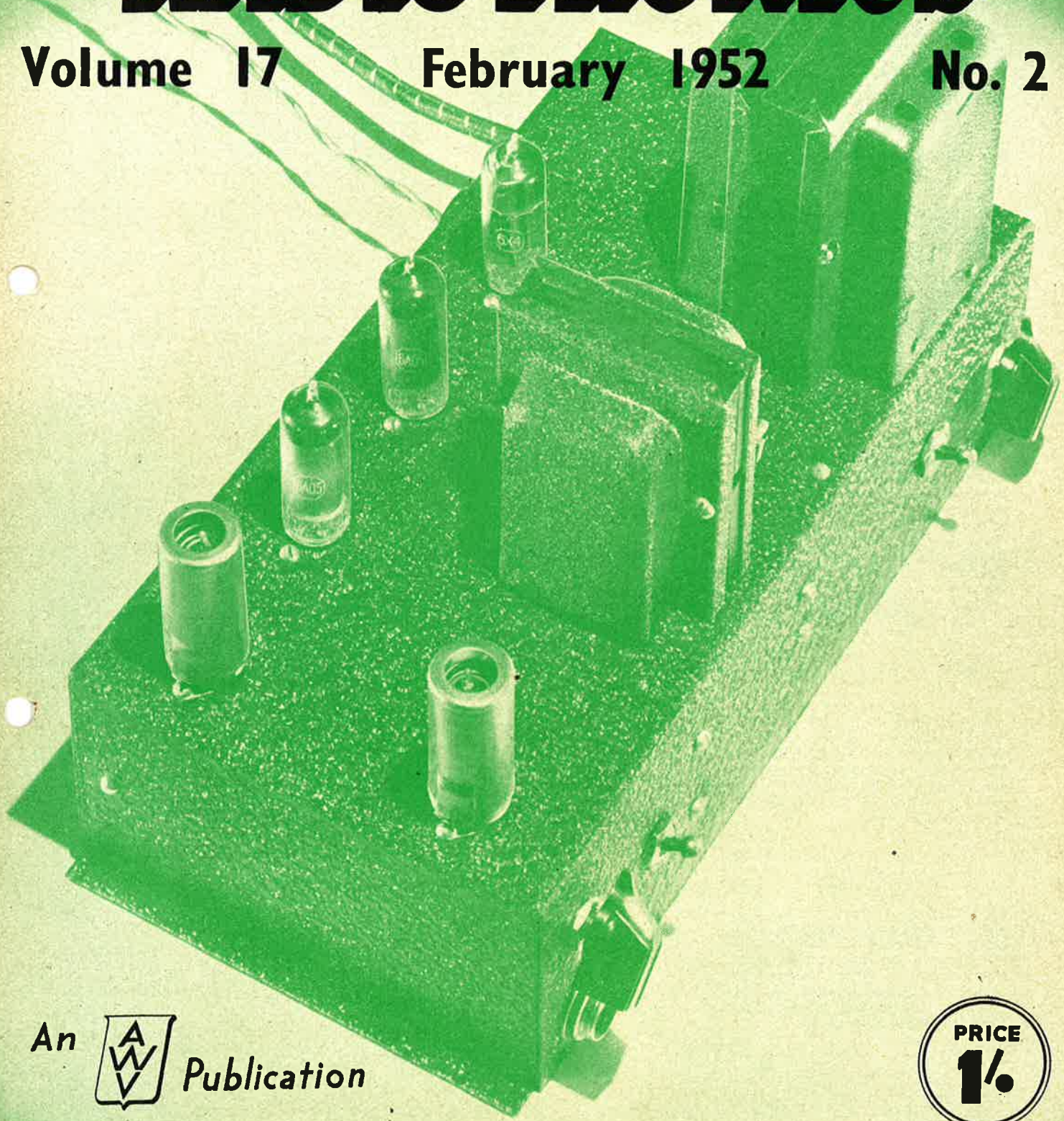

RADIOTRONICS

Volume 17

February 1952

No. 2



An  Publication

PRICE
1/6

Registered at the General Post Office Sydney for transmission by post as a periodical.

RADIOTRONICS

Volume 17

February 1952

Number 2

By the way—

The March issue will continue the sequence of audio articles which commences in the current issue. Subjects to be discussed will include loudspeaker horns and pickup tracking. Amateurs will be interested in a 4 page insert listing commonly-used transmitting valves with typical operating conditions.

Work on a medium - power vibrator-operated class B amplifier is nearing completion in the Circuit Development Laboratory. The output stage employs a pair of triode-connected 6V6-GT valves. Current drain is low, and this amplifier should interest all P.A. equipment designers and operators. Full information will appear in an early issue. — *P. 79.*

No one likes having his name or address misspelt on his mail. If there is anything wrong with the address on your Radiotronics wrapper, please make the correction, cut out and return the address stencil to us. Thank you.

Information concerning new RCA releases published in Radiotronics is intended for information only, and present or future Australian availability is not implied. As an example, this applies to the type 6080 described on page 40.

Editor:
Ian C. Hansen,
Member I.R.E. (U.S.A.).

Asst. Editor:
R. Ainsworth, A.S.T.C.,
A.M.I.R.E. (Aust.).

CONTENTS

	Page
High-Quality LP Amplifier	23
Low-Loss Air-Core Coils	25
Bass Reflex Cabinet Design	28
New RCA Releases	30
Design of Loudspeaker Grilles	31
Logarithmic Compressor	33
Selecting a Loudspeaker	37
Radiotron List of Equipment Types	39
Radiotron Type 6080	40

Radiotronics is published twelve times a year by The Wireless Press for Amalgamated Wireless Valve Company Pty. Ltd. The annual subscription rate in Australasia is 10/-; in U.S.A. and dollar countries \$1.25; and in all other countries 11/-. Price of a single copy 1/-.

Original articles in Radiotronics may be published without restrictions provided that due acknowledgment is given.

Address all communications as follows:—

Amalgamated Wireless Valve Co. Pty. Ltd.,
Technical Publications Department,
G.P.O. Box 2516,
Sydney.

HIGH-QUALITY L-P AMPLIFIER

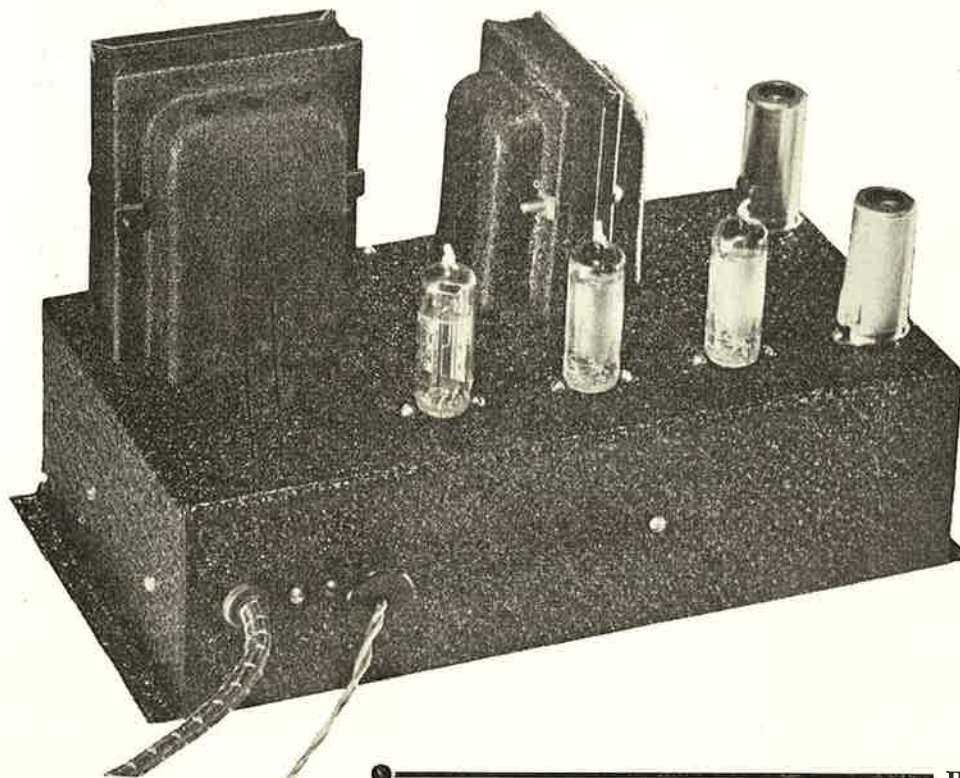

By I. C. Hansen.

Performance

The Radiotron amplifier A519 has been designed bearing in mind the ideas expressed in the introductory article in the December, 1951, issue. It is capable of delivering its rated output of 1.5 watts with much less than 0.5% distortion. Hum and noise combined is 65 db below maximum power output.

The low frequency response of the amplifier at 20 cycles is 0.5 db below the 1000 cycles reference point while high frequency response is limited by a two-step low-pass filter, to 5000 and 8000 cycles respectively.

For rated output, an input of 0.13 volt is required. This can be readily supplied by the Acos GP20 crystal pickup and its associated compensation circuits.

Feedback from the voice-coil of the loudspeaker is employed to reduce the distortion, the gain reduction being 3 times, or 10 db approximately. Even without feedback, the distortion products are quite low.

Radiotronics

Circuit

As push-pull triodes were suggested as providing good results in a simple circuit, it was decided to use a pair of 6AQ5's triode-connected. Under Class A conditions these valves deliver a maximum of 2 watts output with a 250 volt plate supply. Allowing for an efficiency of 80% for the output transformer, 1.5 watts can be expected in the load.

To reduce the plate current of the output stage and so bring the total high tension current within the rating of the 6X4 rectifier, the 6AQ5 bias is increased from -15 to -16 volts. The slight increase in distortion caused thereby, is minimised by a bypass condenser across the push-pull stage cathode-bias resistance.

A normal, split-load type of phase inverter, employing a 6AU6 valve triode-connected, precedes the 6AQ5's, and an additional 6AU6 as a pentode serves as the input stage. While a 6J7-G valve could have been used in place of the 6AU6 pre-amplifier, the overall gain would then not have been sufficient to allow for the use of 10 db of

February, 1952

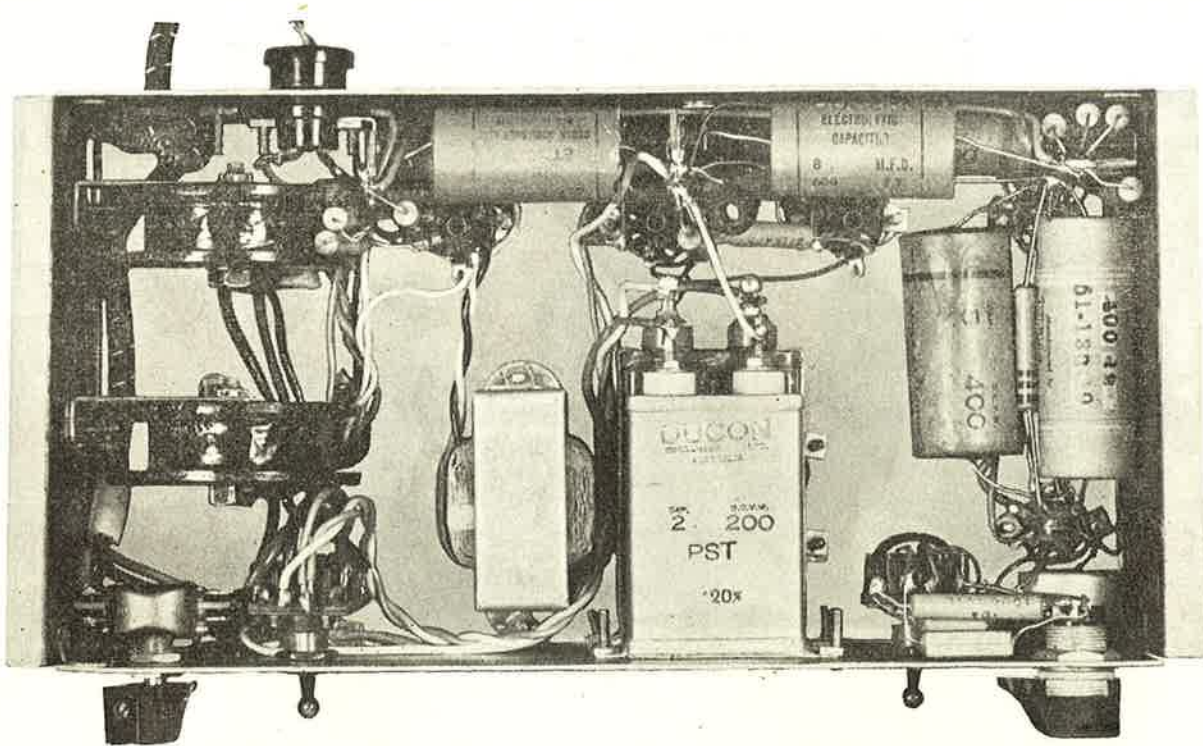

Underchassis view of amplifier showing layout of components.

feedback.

A double-pole, double-throw switch functions to alter the compensation for 78 and 33 r.p.m. recordings.

To achieve the desired limiting of high frequency response, a filter consisting of 2 pi sections is connected in the voice-coil circuit. It should be noted that a transformer of the high-fidelity class with low leakage inductances is not required in this circuit. The reason is that the leakage inductance between primary and secondary becomes part of the first choke in the filter system.

In a similar manner, the cost of a 2 μ F paper condenser can be saved. Instead of placing it across the secondary winding, a much smaller mica condenser can be wired across the whole primary

winding. By virtue of the impedance ratio of the transformer used, a 0.003 μ F condenser from plate to plate of the 6AQ5 valves, appears as equivalent to a 2 μ F condenser across the secondary.

Both choke and condenser values are easily calculated for a 5000 cycle cut-off from formula given on page 228 of Terman's "Radio Engineer's Handbook". Strictly speaking, both component values should be changed if the cut-off frequency is altered. However, in practice, it is satisfactory to leave the condenser values fixed and merely reduce the inductance by suitably tapping the chokes. Methods of choke design appear elsewhere in this issue.

Calculations show that for a 15 ohm output and with a 5000 cycle cut-off, the chokes should have an inductance of 955 microhenries. Measurement of

PERFORMANCE FIGURES.

1. Sensitivity

The input required for 1.5 watts output at 1000 cycles is 130 millivolts.

2. Harmonic Distortion at 1000 cycles.

Output (watts)	0.05	0.25	0.5	0.75	1.0	1.5	2.0	2.5
Distortion (%)	0.09	0.14	0.17	0.24	0.27	0.32	1.2	3.25

3. Noise Level

- (a) Gain control full off — 70 db below 2.5 watts.
- (b) Gain control full on — 65 db below 2.5 watts.

4. Voltage Analysis

		Plate	Screen	Cathode
V. 1	6AU6	62	80	1.9
V. 2	6AU6	170	—	62.0
V. 3 & 4	6AQ5	265	—	16.0
V. 5	6X4	285 r.m.s. per plate.		65 mA d.c. output.

All measurements taken with a 20,000 ohms per volt meter between valve electrodes and ground on the highest scale giving an accurate reading.

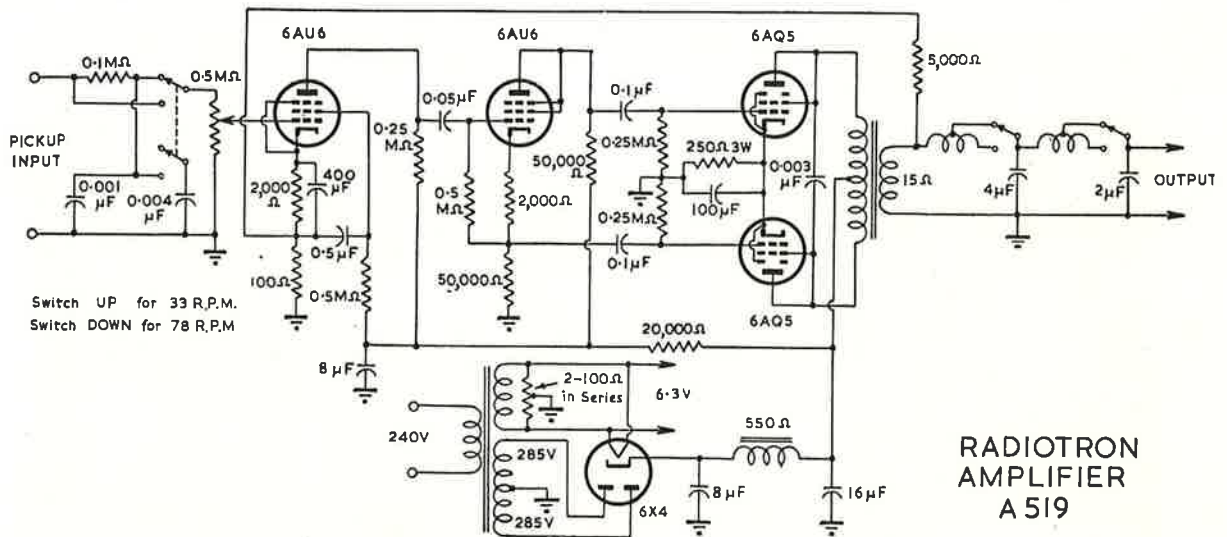

Complete circuit diagram of Radiotron Amplifier A519.

the primary to secondary leakage inductance of the output transformer⁽¹⁾ designed for this amplifier gives the figure as 170 millihenries. When referred to the secondary in the square of the turns ratio (i.e. impedance ratio) this becomes 280 microhenries. Thus the first choke⁽²⁾ in the filter need only be (955-280) or 675 microhenries as 280 microhenries is incorporated in the output trans-

former. By tapping this latter choke at 197 microhenries, and the output choke⁽³⁾ at 477 microhenries, a higher cut-off frequency can be employed. This was measured to be 8000 cycles, for the inductance values quoted. If it is required to raise this for a particular application the coils can be tapped at lower values of inductance.

(1) Ferguson OP 141.

(2) Ferguson CF 150.

(3) Ferguson CF 149.

Low-Loss Air-Core Coil

By I. C. Hansen

From time to time, the necessity arises for the design of air cores having a reasonably high Q at audio frequencies.

Coils such as these are used in frequency dividing networks and filters. An example is the low-pass filter used in conjunction with the amplifier described in this issue.

For the largest inductance in proportion to the d.c. resistance, it is stated* that the circular multi-layer coil with the dimensions as shown in Fig. 1 is the best.

The radius of the circular winding former is taken as l and all the other dimensions are then related to this.

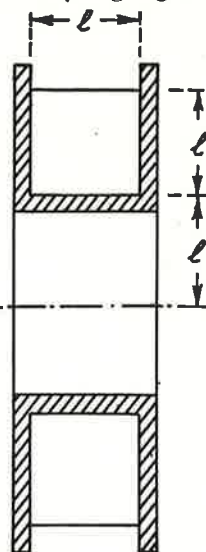

Fig. 1.

For ease of calculation a series of graphs have been prepared based on coil radii of 0.25, 0.375, 0.5 and 0.75 and 1 inch. Knowing the inductance required, and having chosen a likely winding radius for a first trial, the required number of turns is read off from Fig. 2. The required A.W.G. (B & S) wire gauge size is then obtained from Fig. 3 and finally the d.c. resistance of the coil from Fig. 4. An example will make this clearer.

Assume an inductance of 1 millihenry is required with a resistance of less than 0.75 ohm. Selecting a coil radius of 0.375 inch, Fig. 2 shows that 200 turns will be required. Fig. 3 indicates that the A.W. gauge number is 22.3. This means that the next smaller gauge, 23, must be chosen for the required number of turns to fit the space. From Fig. 4 the coil resistance is then shown as 1.4 ohms. As this is too large, the next bigger coil radius, 0.5 inch is chosen and it is then found that the finished coil will have a resistance of less than 0.6 ohms which is satisfactory.

*"Radio Engineers' Handbook" Terman, F. E., Page 89.

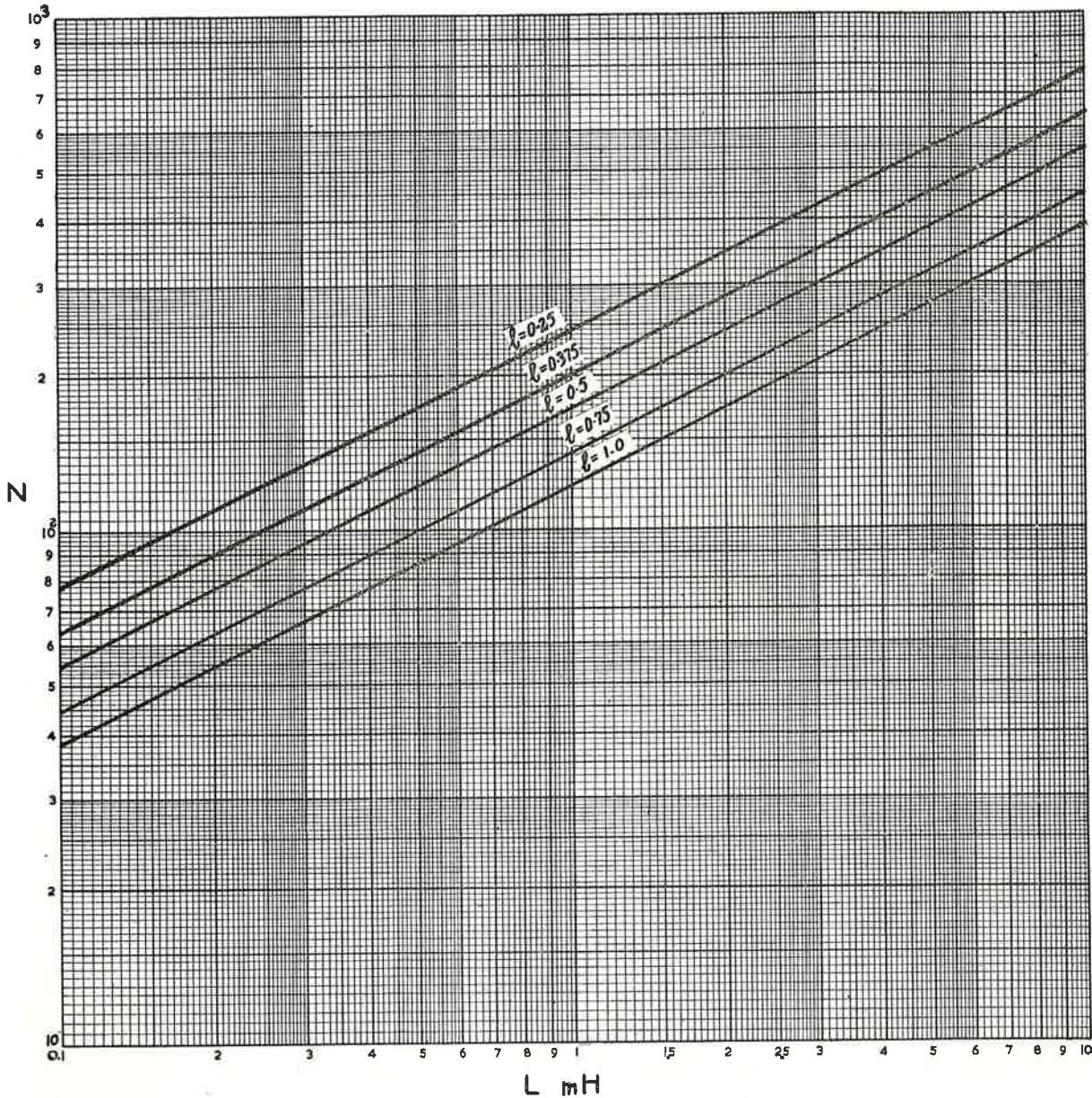

Fig. 2. Determination of N given L and l .

The approximate weight of the wire used for fully-wound coils of each size is shown below, the weight being proportional to l^3 .

l inches	Weight ounces
0.25	0.5
0.375	1.75
0.5	4.25
0.75	14
1.00	33

The Q of an air coil is directly proportional to the frequency and for coils having the specified ration of dimensions, Q is also proportional to l^3 . At 1000 cycles, the maximum Q obtainable with fully-wound coils regardless of wire gauge or inductance, is shown here for various coil radii.

In general, the average Q obtained in practice will be about 25% lower than these figures.

l inches	Q 1000 \sim
0.25	2.75
0.375	6.5
0.5	11.5
0.75	26
1.00	48

It will be seen that the cross-section of the coil is square, thus the number of layers in the coil will be the same as the number of turns per layer. The latter, of course, will be found from the square root of the number of turns.

It is recommended that enamelled wire be used

(Continued on page 32)

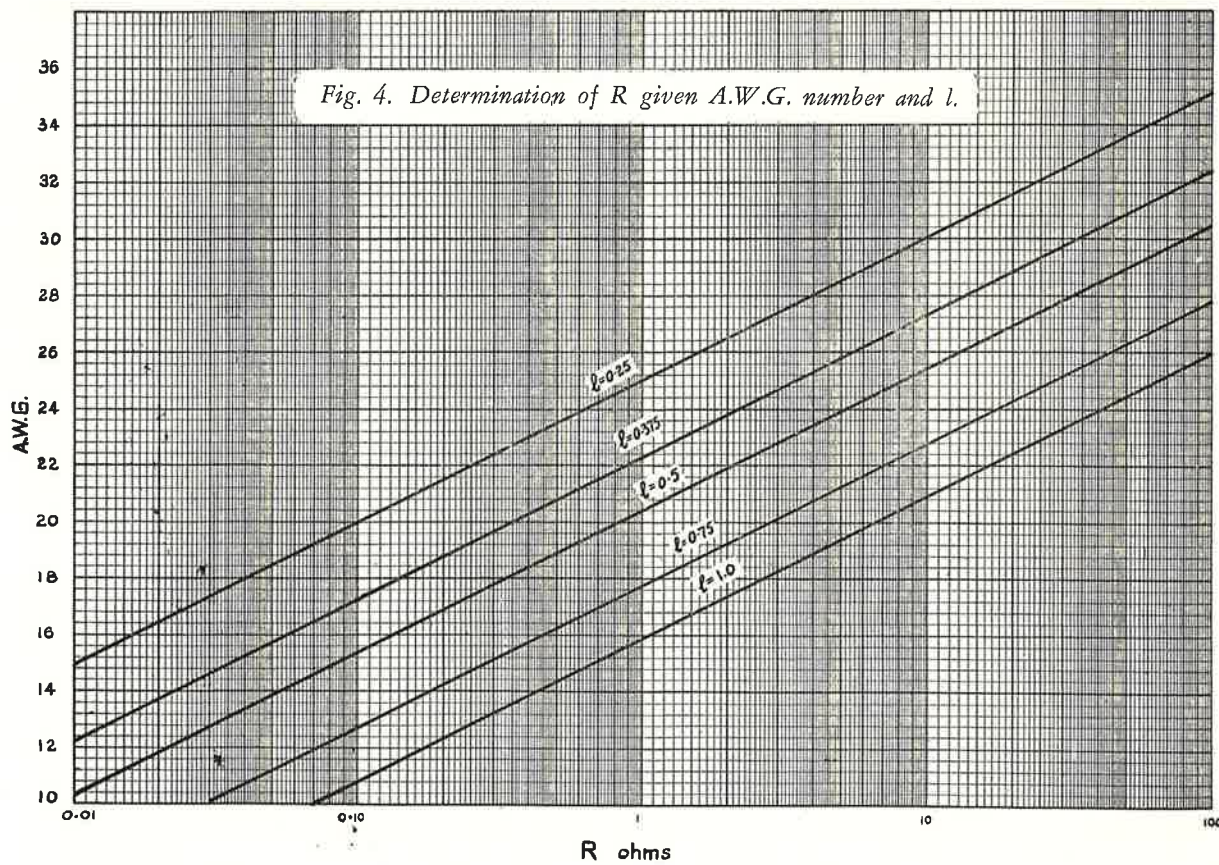
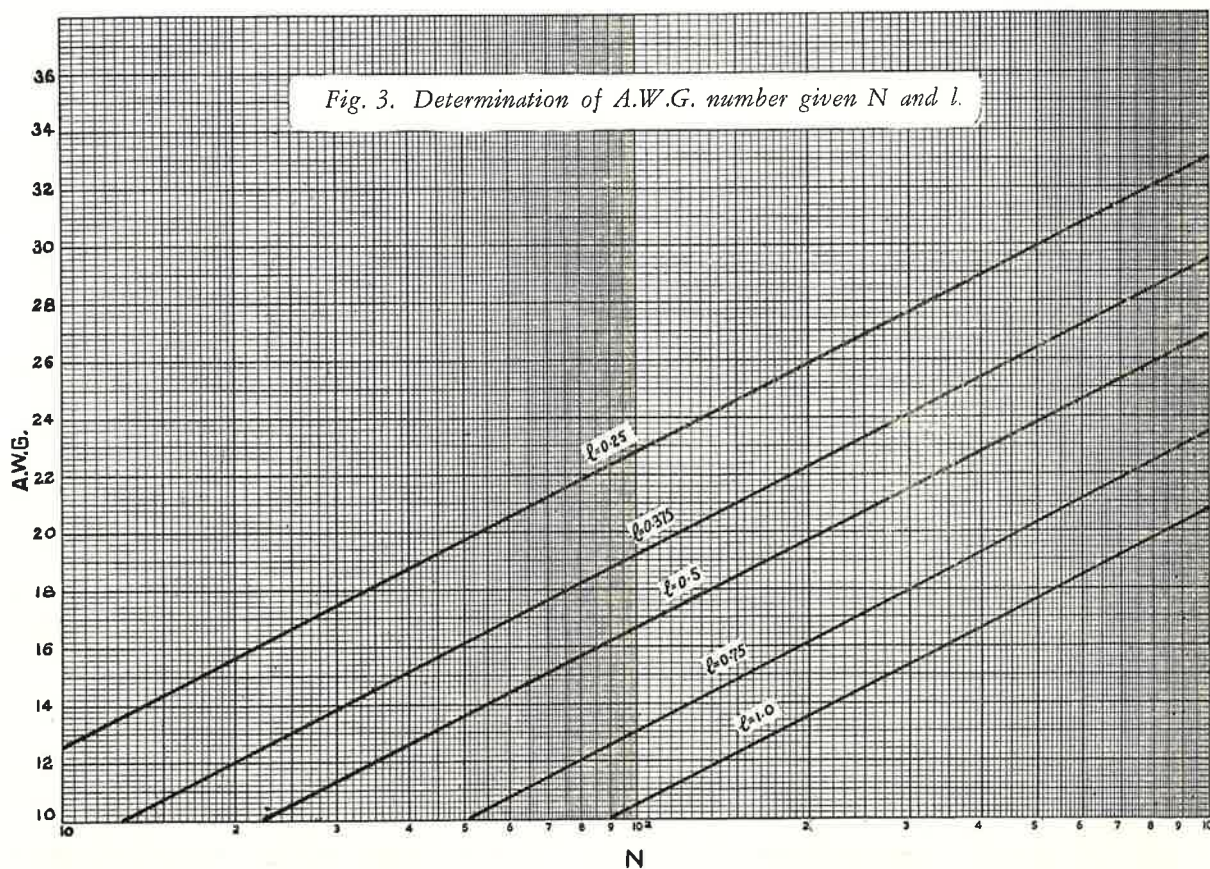

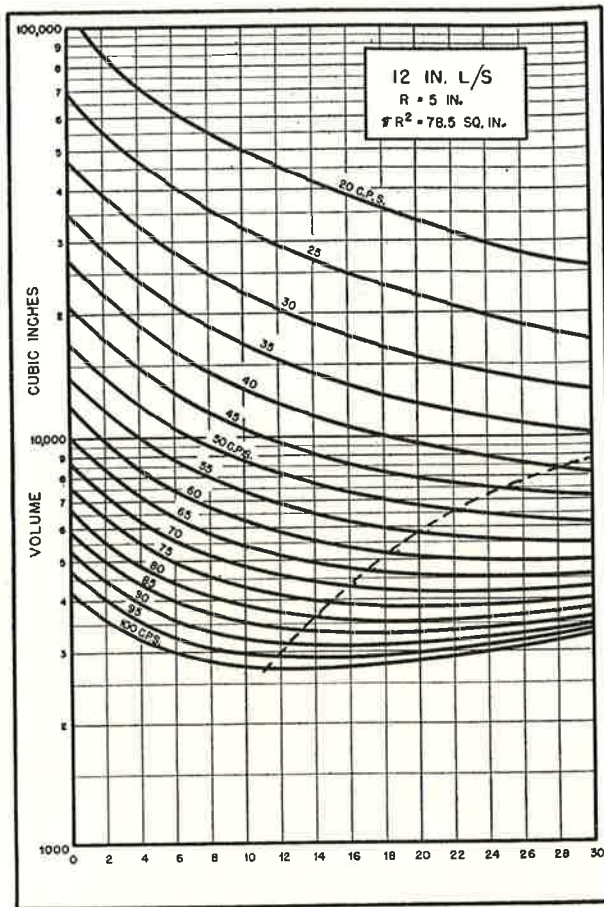
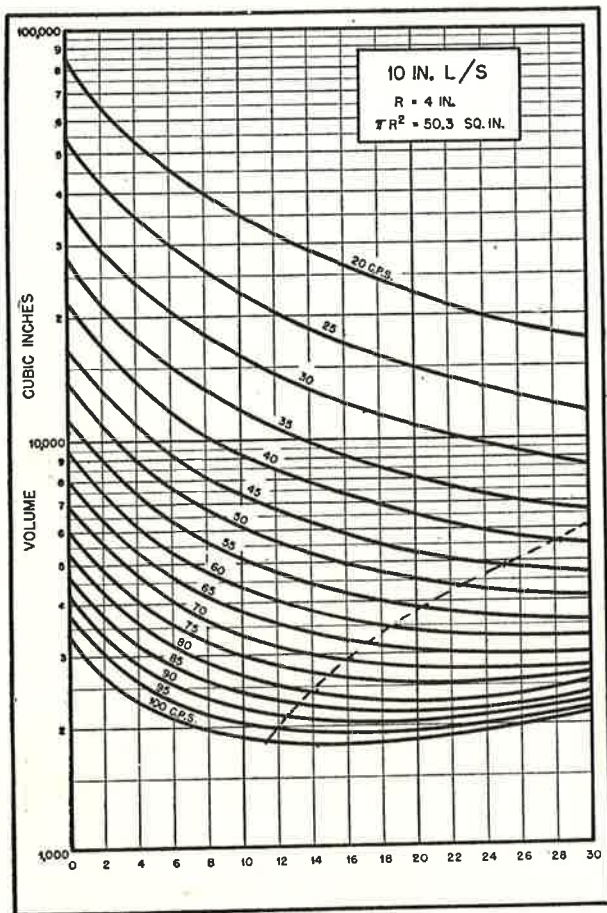

Bottom rows of figures indicate tunnel length in inches.

BASS REFLEX CABINET DESIGN

For the benefit of our readers who are interested in better baffles for their speakers, we have abstracted some information from an article by J. A. Youngmark which appeared in the September, 1951 issue, of "Audio Engineering" on the above subject.

In the normal domestic installation there is much to recommend the bass-reflex design. Correctly designed, it gives increased power handling capacity, reduces the cone amplitude distortion at the resonant frequency, and at the same time gives additional output at this frequency. It may be built in a compact form and is relatively free from phasing difficulties.

The author points out that the overall size of the vented baffle can be reduced appreciably, by the introduction of a tunnel projecting into the speaker cabinet. As a further step towards making the vented baffle "socially presentable", he gives the

constructional details of a cabinet of triangular shape that can conveniently and unobtrusively fit into a living-room corner.

His article is illustrated by four graphs which we reproduce here by kind permission of "Audio Engineering". Reference to these will demonstrate the ease with which a suitably sized cabinet can be designed.

Assuming you have a 10-inch loudspeaker with a bass resonant frequency of 70 cycles, the cabinet volume required when no tunnel is used, is seen to be 7000 cubic inches approximately. This volume can be halved by using a 9-inch tunnel. All these figures are read off the graph titled "10 inch loudspeaker". It should be noted that the volume thus given is nett and must be increased by the volume of the loudspeaker and any bracing struts used in the cabinet interior.

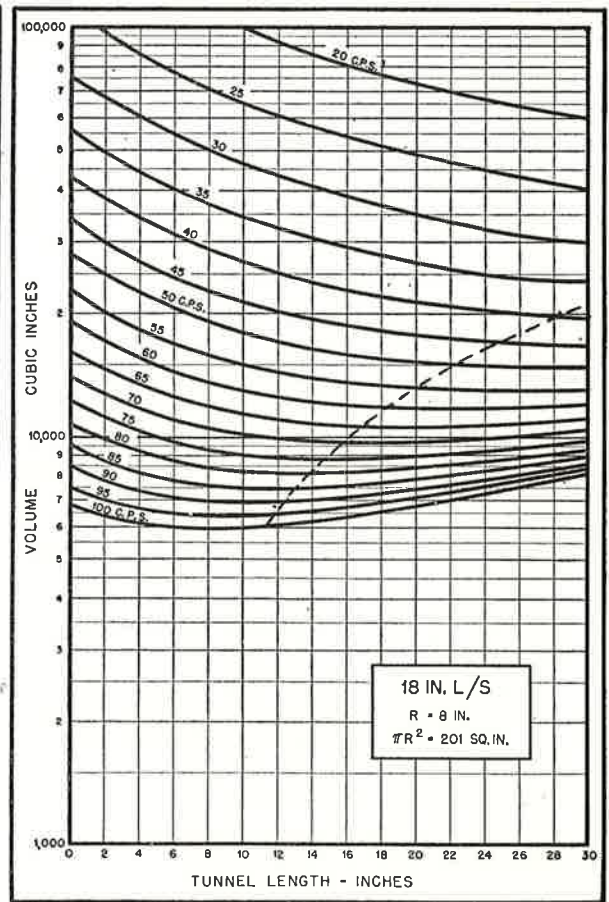
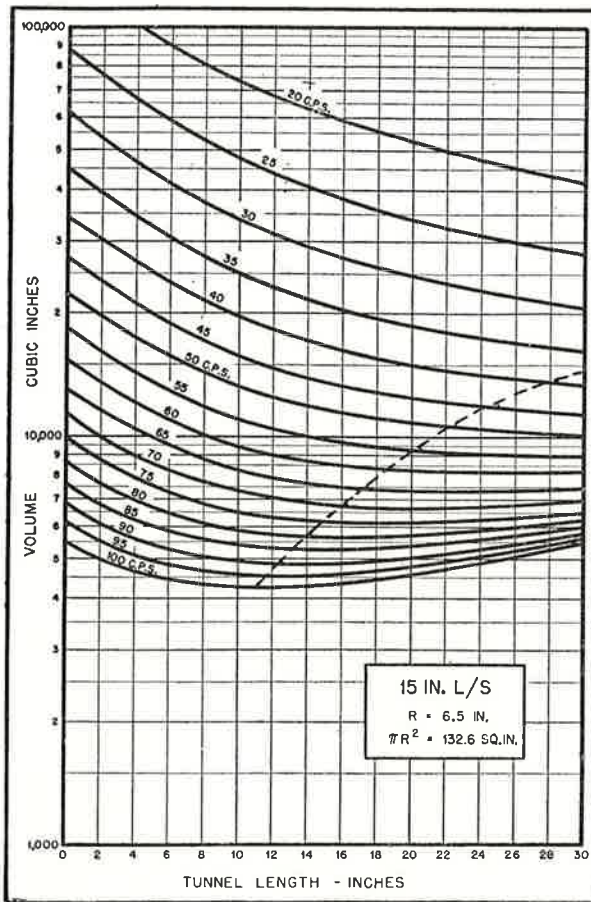

In selecting a suitable tunnel length, the following should be borne in mind.

(a) The length L , of the tunnel should not be greater than $1/12$ of the wavelength of the speaker bass resonant frequency. Points to the right of the dotted lines which represent this limit should not be used.

(b) The tunnel should not approach the back of the cabinet too closely but should be spaced away by a distance at least equal to R . For the value of R , see the relevant size speaker graph.

(c) As L is increased towards its maximum, it will be found that in general, the ratio of the cabinet dimensions is not very harmonious.

(d) The resonant frequency of the cabinet depends less on its position in the room as L is increased.

(e) As L is made longer, the cabinet volume becomes less.

(f) The tunnel can be any shape, provided that its cross-sectional area is πR^2 . This value is shown on each graph and for a 12-inch speaker is

78.5 square inches. In this case the vent hole could be 12 by $6\frac{1}{2}$ inches.

The cabinet illustrated has a volume of approximately 8000 cubic inches and is designed for use with a 12-inch speaker having a cone resonance of 55 cycles. It should be made of $\frac{3}{8}$ to 1 inch timber or plywood, solidly glued and screwed together and lined with an inch of hair felt.

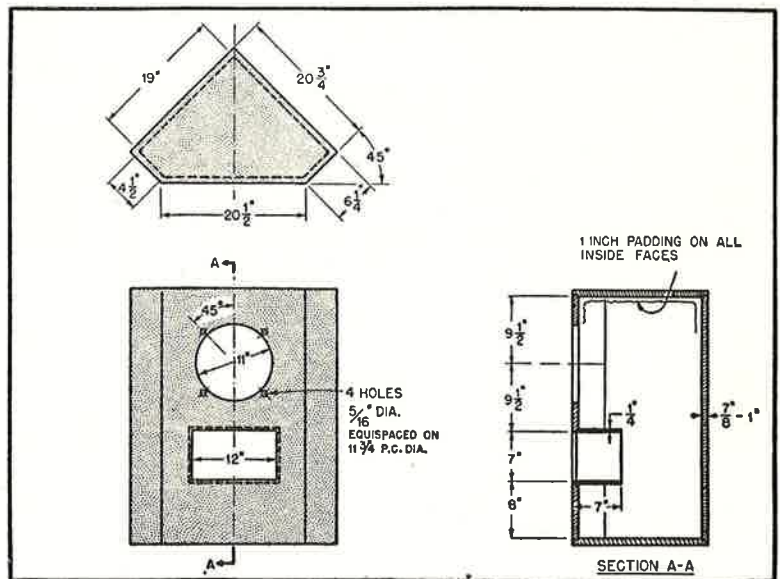

New RCA Releases

The **Radiotron 3JP1** is a 3-inch cathode-ray tube of the electrostatic-focus and electrostatic-deflection type having unusually high spot intensity, high grid-modulation sensitivity, and high deflection sensitivity. It is intended particularly for general oscillographic applications in which a high-intensity trace is needed.

The 3JP1 utilizes a medium-persistence screen having green fluorescence and phosphorescence. The screen has high visual efficiency and exceptionally good brightness contrast between the scanned line and the background. Because of its medium-persistence screen, the 3JP1 is particularly useful where either medium-speed non-recurring phenomena or medium- and high-speed recurring phenomena are to be observed. The persistence is such that the 3JP1 can be operated with scanning frequencies as low as 20 cycles per second without excessive flicker.

Like its companion 3JP7 with long-persistence screen, the 3JP1 is designed with a high-voltage, post deflection accelerator electrode. This electrode makes possible a high-intensity fluorescent spot with minimum sacrifice in deflection sensitivity and with slight increase in spot size. Because of the high efficiency of the electron gun, large changes in the spot intensity can be obtained with small variations in control-grid voltage.

The electron gun employed in the 3JP1 has a grid No. 2 operated at constant voltage so that the beam current and grid No. 1 cutoff voltage will not be affected by focusing adjustment. Because of the effect of grid No. 2 and the negligible current taken by anode No. 1, the spot can be sharply focused on the screen and remains sharp when beam current is varied over a wide range. The very small anode—No. 1 current permits the use of a low-current voltage-divided system and hence the use of a small filter capacitor.

Other design features of the 3JP1 include large useful screen surface in relation to bulb diameter; separate base-pin connections for each of the four deflecting electrodes; balanced deflecting-electrode input capacitances to minimize "cross-talk" and to eliminate the necessity for neutralizing circuits; and the diheptal 12-pin base which enables the 3JP1 to be operated at its rated maximum values under reduced atmospheric pressure equivalent to an altitude of 40,000 feet.

The **Radiotron 5FP14** is a 5-inch cathode-ray tube of the magnetic-focus and magnetic-deflection type intended particularly for those oscillographic applications, such as radar indicator service, where grid No. 1 is pulse-modulated at high frequency to provide a temporary record of electrical phenomena. It utilizes the medium-long persistence phosphor P14.

Because of its medium-long persistence, the 5FP14 is particularly useful where either low- and medium-speed non-recurring phenomena or high-speed recurring phenomena are to be observed. The persistence is such that the 5FP14 without filter can be operated with scanning frequencies as low as 30 cycles per second without excessive flicker. When used with yellow filter, such as Wratten No. 15, the 5FP14 can be operated with much lower scanning frequencies.

The 5FP14 utilizes an electron gun which features a limiting aperture at the end of the gun to produce a sharper, rounder spot on the screen, especially when the tube is operated at high beam current, and hence provides greater effective resolution. Because of this feature, this type is especially useful in those applications where pulse-modulated operation requires high grid No. 1 drive and resultant high beam current.

The **Radiotron 17TP4** is a 17-inch, metal-shell picture tube utilizing Low-Voltage Electrostatic Focus—an achievement in picture-tube design, which in addition to eliminating the need for a focusing coil or magnet, makes it possible to obtain the focusing-electrode voltage from the low-voltage dc supply of the receiver.

The focusing electrode in the 17TP4 has its own base-pin terminal to permit choice of focusing voltage for best results. The focusing voltage range within which a cathode-ray tube gives optimum focus will change with different combinations of ultr and grid-No. 2 voltages. Adjustments for this change is made possible by the separate focusing-electrode terminal.

Because the focusing electrode operates at low voltage, the focusing voltage can conveniently be obtained from a fixed or adjustable tap on the low-voltage dc supply of the receiver. With either method, focus is maintained automatically with variation in line voltage and with adjustment of picture brightness.



When fixed focus is used, the designer can set the focusing voltage at a value which will give good results for his particular operating voltages. If somewhat better performance is desired, he can provide for adjustment of the focusing voltage.

Using a design in which the cathode is not connected to any other electrode, the 17TP4 retains the advantage of low input capacitance when employed in a cathode-drive circuit. Also, since the focusing electrode is not connected internally to grid No. 2, the 17TP4 has the advantage of permitting reduction in focusing voltage as grid-No. 2

(Continued on page 32)

Design of Loudspeaker Grilles

LEO. L. BERANEK

What sort of grille is acceptable for use in front of a loudspeaker? Actually, this question can be answered very simply in a qualitative way. A grille must not attenuate any of the tones radiated by the loudspeaker diaphragm. The attenuation produced by the grille will be negligibly small if it has a very low "flow resistance". That is to say, it must offer very little opposition to the flow of air through it.

As a simple test of the lowness of the flow resistance, I suggest that you stand facing another person and talk in a normal tone of voice. Then, while you are talking, bring a foot square sample of the grille cloth in front of your lips. If the person listening to you is not able to detect a change in the quality of the high frequency sounds of your voice, the chances are excellent that the cloth is satisfactory.

For most people this answer is too simple. They prefer a more precise measure of the attenuation. We have the answer for them also. First, let us divide grilles into three categories:—

A. Those that have large enough openings so that they offer no opposition to air flow and whose only purpose is to keep large objects such as golf balls from striking the cone of the loudspeaker.

- B. Those that have facings perforated with small holes.
- C. Those that can be classed as resistive cloths.

Type A offers no acoustical design problem and requires no discussion here.

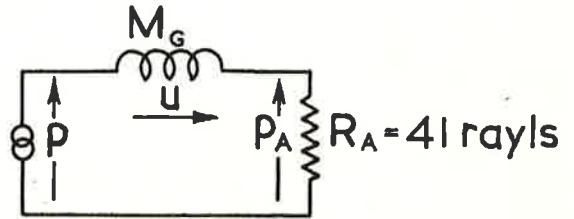

Fig. 1.

Type B can, in combination with the radiation impedance of the air, be handled by the schematic diagram of Fig. 1. In this figure, the particle velocity u is an analogous to current and the sound pressure p at the inside face of the perforated facing is analogous to voltage. The radiation resistance R_A is equal to 41 rays under standard temperature and pressure conditions. The sound pressure p_A is the sound that exists on the room side of the grille cloth. The goal is to make p_A as near to p as possible.

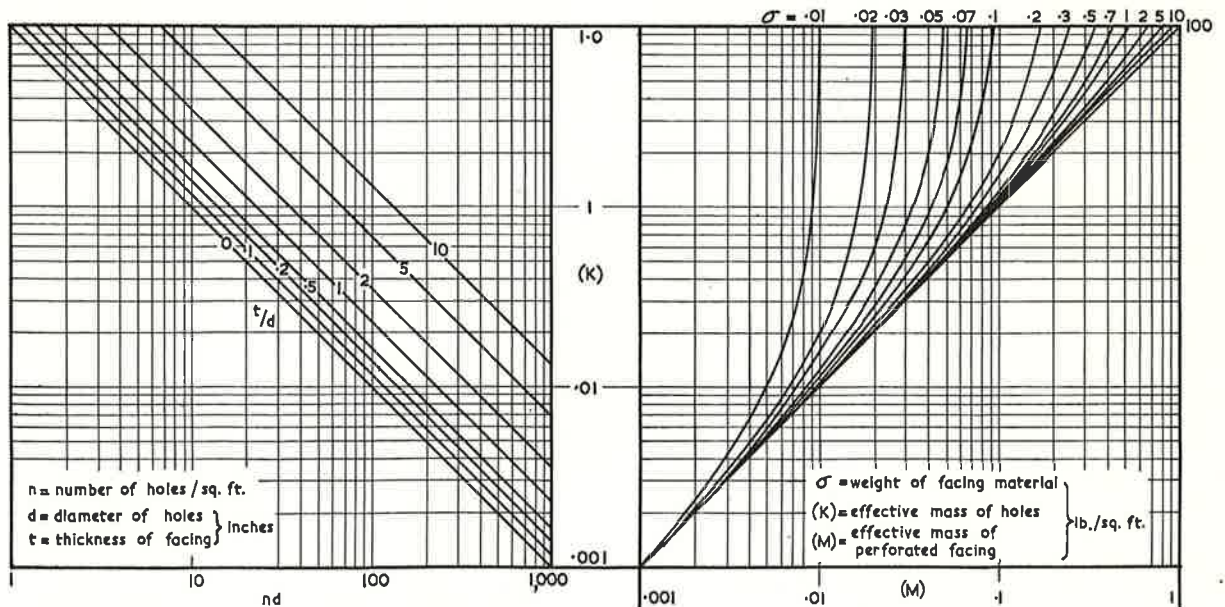

Fig. 2.

Reprinted from the Newsletter of the Professional Group on Audio by courtesy of the I.R.E. (U.S.A.).

If the resistance of M_G is to be small compared to the radiation resistance R_A , the facing must be very thin and the holes must occupy a very large percentage of the total area of the grille. The magnitude of M_G has been discussed by R. H. Bolt, in the "Journal of the Acoustical Society of America," Vol. 19, p. 917-921, September, 1947. He presents the charts of Fig. 2. It will be noted that the charts are drawn in English units. To convert from value of M shown on the charts in pounds per square foot to the value of M_G in grams per square centimeter, divide M by 2. To use Fig. 2, enter the abscissa of the left-hand graph with the product of nd . Pass upward to the value of i/d and then to the right to determine the quantity K . Then entering the ordinate of the right-hand chart, move to the right to the value of σ , and determine M from the abscissa. Convert M to M_G by dividing by 2 and use this value in Fig. 1 to determine the effect of the grille. If the grille cloth is not to reduce the sound pressure p_A , its impedance must be small compared to the radiation impedance R_A . No extensive tables of the properties of cloths are published. I find in my files information on five kinds of cloths which have found use in the past. Their properties are as follows:

1. **Aristo.** Cotton cloth, simple weave, 32 threads per inch, 8.2 oz. per sq. yd., $R_G = 14$ rayls.
2. **Planet Suede.** Cotton cloth, fuzzy finish, thread count not known, 5.2 oz. per sq. yd., $R_G = 23$ rayls.
3. **Mummy Cloth.** Cotton, 12 heavy threads in one direction and 12 light threads in the other direction, 7.6 oz. per sq. yd., $R_G = 27$ rayls.

NEW RCA RELEASES *(from page 30)*

voltage is raised—a necessary relationship for optimum focus.

The **Radiotron 3B28** is a xenon-filled, half-wave rectifier tube of the coated filament type featuring an ambient-temperature operating range of -75° to $+90^\circ\text{C}$, low voltage drop, rugged construction to permit use under conditions of severe vibration, and no restrictions on mounting position.

The 3B28 is rated at (1) a peak inverse anode voltage of 10,000 volts and an average anode current of 0.25 ampere, or (2) a peak inverse anode voltage of 5000 volts and an average anode current of 0.5 ampere.

In single-phase, full-wave service, a pair of 3B28's will provide a dc output current of 1 ampere at 1600 volts to the filter when the peak inverse anode voltage is limited to 5000 volts, or 0.5 ampere at 3200 volts when the peak inverse anode voltage is 10,000 volts.

LOW-LOSS AIR-CORE COILS

(Continued from page 26)

and that when such coils are used in voice coil circuits no interlayer insulation be employed as the operating voltages are quite low.

4. **Mohair Automobile Upholstery.** Wool 13.7 oz. per sq. yd., $R_G = 200$ rayls.
5. **Muslin.** Cotton cloth, about 50 threads per inch, 3.9 oz. per sq. yd., $R_G = 42$ rayls.

Substitution of the values for R_G and M_G from the above tabulation into the circuit of Fig. 3 reveals that only the Aristo cloth is good enough for use as a loudspeaker grille.

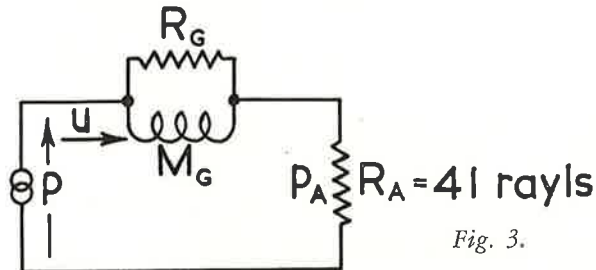

From my own experience with cloths, I believe that the most suitable type of cloth is one which is very loosely woven and which has hard threads. Fuzzy threads increase the resistance R_G . If the resistance is low enough, the mass per square centimeter is unimportant. Perhaps the best type of grille is an open mesh, plastic-thread cloth such as is sometimes found on the modern radio cabinet.

The performance of the Type C grille is represented by the circuit of Fig. 3. In this figure, R_G is the flow resistance of the resistive cloth in rayls and M_G is the weight of the cloth in grams per square centimeter. (Note that a weight of one ounce per square yard equals 0.0034 grams per square centimeter.)

A cardboard, plastic or wooden former should be used and mounted by a brass bolt through the centre of the former. Steel bolts should not be used. In a typical instance, a 3/16 inch brass bolt through a coil, of 1/2 inch winding radius caused a reduction in inductance of 10%. A 5% increase in calculated turns corrected the inductance to the desired value.

CINTEL PHOTOTUBES

In the bulletin dealing with Cintel Phototubes issued with "Radiotronics", it was stated that the Cintel equivalent of the 868 was their GS118.

We have now been advised that the GS146 is a more exact replacement, and therefore after our existing stocks of GS118 are exhausted we will be supplying type GS146 in lieu thereof.

A further change is that the 918 Cintel equivalent is now the GS146 special grade, rather than the GS146 as formerly.

It is suggested for future reference that these amendments be made to your Cintel bulletin, additional copies of which are still available free on request from this office.

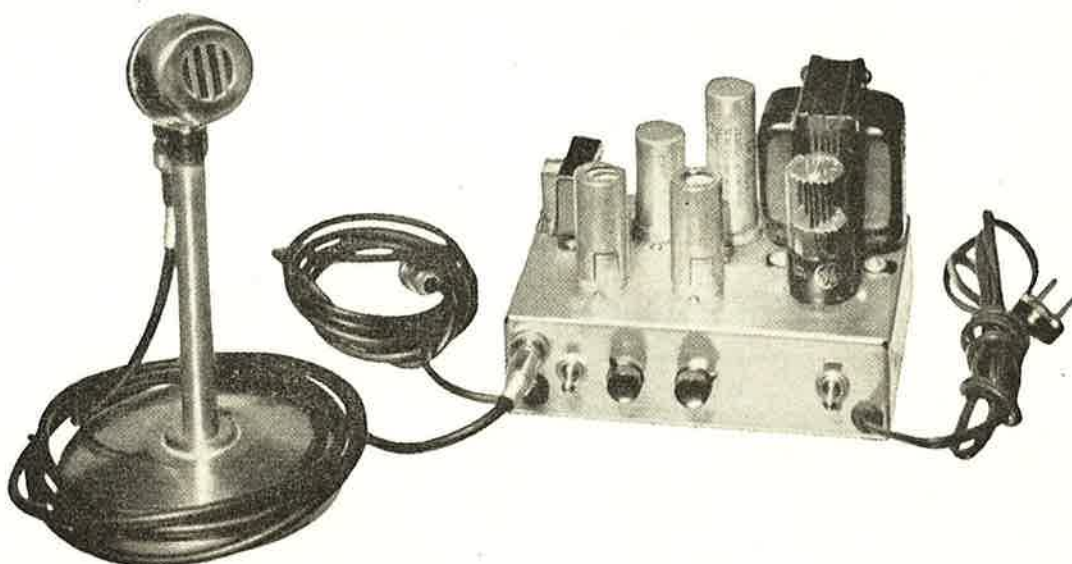

Fig. 1. The Logarithmic Compressor ready to plug into your present microphone jack. Controls are, left to right, in-out switch, compression control, output control and a.c. on-off switch.

LOGARITHMIC COMPRESSOR

Every phone man, at some time in his QRM-ridden life, has wished that he had a small switch available which would permit him magically to increase his power tenfold. This would be Utopia — from one kilowatt to ten kilowatts by pressing a button.

This button is now available, and it is mounted on the front of the Logarithmic Compressor. This unit will give an effective signal gain which is adjustable from a few db up to as much as ten db (ten to one in power).

The Logarithmic Compressor is an audio amplifier device which is inserted between your microphone and your present speech amplifier. Its function is to push up the average modulation level, with the result that high percentage modulation is assured at all times, regardless of the sound level reaching the microphone.

Compression vs. clipping

Those familiar with clippers or clipping circuits can see that the Logarithmic Compressor is intended to do the same sort of job as a clipper. There is, however, an important difference between logarithmic compression as used in the Logarithmic Compressor and clipping.

Reprinted from Ham News by courtesy of A.G.E. with acknowledgements to International General Electric.

Fig. 2 compares the characteristics of the two different systems. In either case the input wave suffers distortion, but the distortion caused by the clipping action of the ordinary diode type clipper (Fig. 2B) is worse for a given amount of signal compression than that caused by the logarithmic compression of a copper-oxide instrument rectifier (Fig. 2A).

Distortion present in either circuit will add "harshness" to speech signals and without further treatment would result in excessively broad signals. Therefore, any distorting type circuit should be followed by a suitable filter to prevent the high frequency products produced by this distortion from reaching the modulated stage. With such a filter much of the "harshness" will still be present but the radio-frequency signal need not be broad. The harshness results from cross modulation (distortion) products that lie within the pass band of the filter.

The advantage of the logarithmic compression system is that the distortion is less severe (for a given amount of compression) than the clipper type, and this makes possible the use of a vastly simpler filter arrangement. Three "stages" of R-C type filtering used in the Logarithmic Compressor are as effective as more elaborate sharp-cutoff types of L-C filter virtually necessary with the clipper type of circuit.

TRANSFER CHARACTERISTIC OF BACK-TO-BACK
COPPER OXIDE INSTRUMENT RECTIFIER

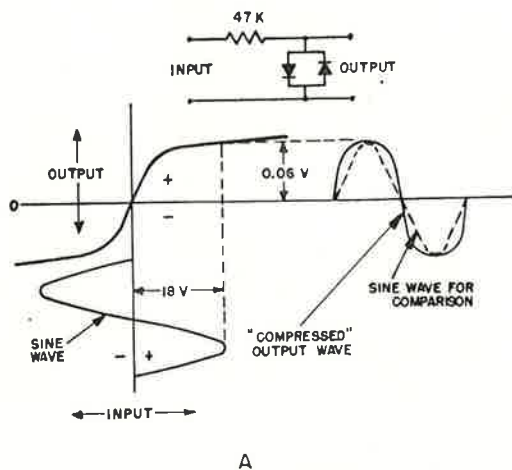

TRANSFER CHARACTERISTIC OF
USUAL DIODE CLIPPER CIRCUIT

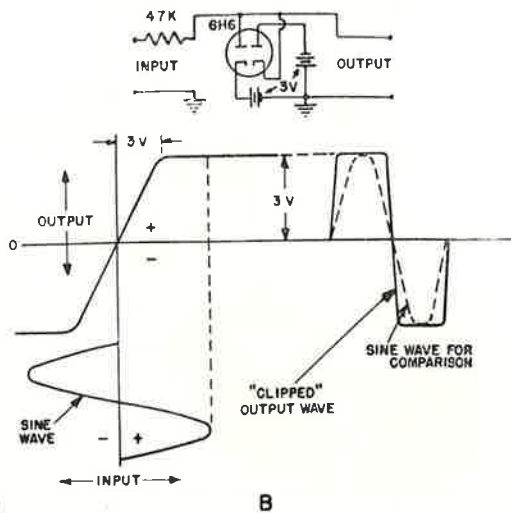

Fig. 2. A comparison between the output waveform of a Logarithmic Compressor and a diode clipper.

Further, the transient response of the $R-C$ type filter is such that no overshoot of signal peaks can occur. This is not the case with sharp-cutoff $L-C$ filters. This means that the logarithmic compressor circuit with a properly designed $R-C$ filter is superior to the ordinary clipper circuit followed by a sharp $L-C$ filter. Repeated tests confirm this statement.

Circuit details

With reference to Fig. 3 it will be seen that the first 12AT7 acts as a two stage audio amplifier to bring the signal from the microphone to a sufficient level so that the compression circuit itself operates at the proper level. Resistor R_1 in the first stage has been added as a precaution against radio-frequency feedback.

Special care has been taken to attenuate low audio frequencies prior to compression. Doing this gives a well balanced speech response as well as minimizing much of the distortion caused by cross-modulation between the low speech frequencies and the *intelligence-bearing* high speech frequencies. The values of condensers C_2 , C_3 and C_4 are chosen to attenuate the low frequencies adequately before speech compression. Condensers C_7 and C_9 serve the same purpose after compression has taken place.

Resistor R_4 , by varying the signal input to the second section of the first 12AT7, enables control of the amount of compression.

The audio transformer, T_1 , is necessary because the limiting circuit must be fed by a low-impedance, low-resistance source. Using the centre-tap on this transformer accomplishes this function.

The actual limiting or compression circuit consists only of R_7 and W , the latter being two sections of a copper-oxide instrument rectifier. Resistors R_8 and R_9 , together with condensers C_5 and C_6 act as a two-section $R-C$ filter. The output of this filter feeds the second 12AT7 directly. Resistor R_{12} acts as an output control so that the output level from

the speech compressor may be made to match the output level of the microphone. Thus when the speech compressor is switched out of the circuit no other adjustment need be made.

The output tube is required for two reasons. It is necessary to present the proper load to the two $R-C$ filters and, secondly, to permit a third $R-C$ stage to be utilized. Inasmuch as the second section of the 12AT7 tube is not used this may seem like wasting part of the tube, but the use of a high- μ triode was dictated and the 12AT7 fills this requirement nicely. Note that the heater of the unused section need not be energized. Many uses for this extra tube section will undoubtedly suggest themselves.

The in-out switch, S_2 , allows the unit to be switched in and out of the circuit easily. Note that shielded wire is specified for the connections to this switch. The output itself is carried by a shielded lead which plugs into the mike jack of any speech amplifier designed to handle a high impedance dynamic or crystal microphone.

The power supply is conventional in all respects. Because of the low current drain on the power supply a resistor-capacitor filter is employed. Resistor R_{18} and condenser C_{11} provide decoupling and additional filtering for the first 12AT7 section plate voltage.

The connections indicated by the heavy black lines in the power supply section should all be made to one ground point. This will prevent the chassis from carrying the circulating capacitor current and help to keep the unit hum-free.

Constructional details

As may be seen from the photographs, the entire unit, including power supply, is mounted on a 5 by 7 by 2 inch chassis. While the layout is not critical, it is advisable to keep the power supply portion of the circuit as far away from the rest of the circuit as possible. The layout shown is quite satisfactory.

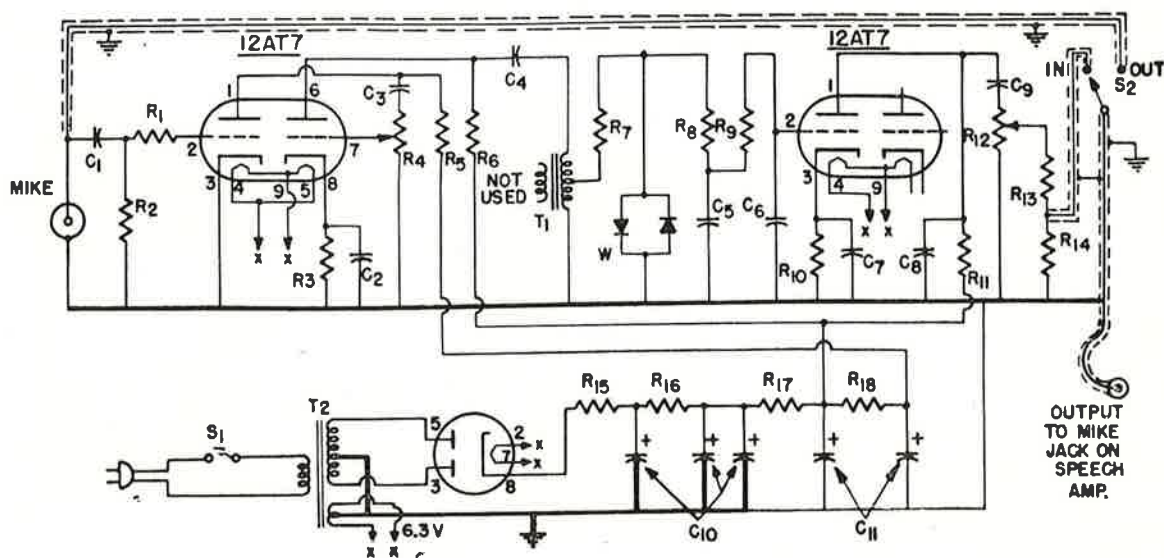

Fig. 3. Circuit diagram of the Logarithmic Compressor.

CIRCUIT CONSTANTS

(All resistors and capacitors $\pm 20\%$ tolerance unless specified otherwise)

C_1, C_9	0.01 μF 400 volt paper or mica	R_9	0.56 megohm, $\pm 10\%$, $\frac{1}{2}$ watt
C_2, C_7	1.0 μF paper (see text)	R_{12}	0.1 megohm potentiometer
C_3	1000 $\mu\mu\text{F}$ mica	R_{13}	0.47 megohm, $\frac{1}{2}$ watt
C_4	0.05 μF 400 volt paper	R_{15}	470 ohm, 2 watt
C_5	1000 $\mu\mu\text{F}$ $\pm 10\%$ mica	R_{16}	2200 ohm, 2 watt
C_6	100 $\mu\mu\text{F}$ $\pm 10\%$ mica	R_{17}	1000 ohm, 1 watt
C_8	0.005 $\mu\mu\text{F}$ $\pm 10\%$ mica	R_{18}	4700 ohm, 1 watt
C_{10}	15-15-15 μF 450 volt electrolytic (see text)	S_1	SPST toggle switch
C_{11}	10-10 μF 450 volt electrolytic	S_2	SPDT toggle switch
R_1, R_{14}	10,000 ohm, $\frac{1}{2}$ watt	T_1	Push-pull plates to voice coil audio transformer, UTC R-38A (see text)
R_2	10 megohm, $\frac{1}{2}$ watt	T_2	Power transformer, 285-0-285 volts at 50 mils, 6.3 volts at 2 amperes
R_3, R_{10}	470 ohm, $\frac{1}{2}$ watt	W	Copper-oxide instrument rectifier (see text)
R_4	0.5 megohm potentiometer	Rectifier	6 X 4
R_5	0.1 megohm, 1 watt		
R_6, R_{11}	47,000 ohm, 1 watt		
R_7	47,000 ohm, $\frac{1}{2}$ watt		
R_8	56,000 ohm, $\pm 10\%$, $\frac{1}{2}$ watt		

With reference to Fig. 1, the front panel layout, from left to right, is: mike jack, output lead, in-out switch, compression control, output level control, a.c. on-off switch and a.c. cord. The tubes are, left to right, input 12AT7, output 12AT7 and 6X5 rectifier. Note that the two 12AT7 tubes are shielded.

Fig. 4 gives the details of the wiring. Nothing here is critical if normal wiring procedure is followed. Note that R_1 is placed as close to the grid pin as possible.

The wiring can be made simpler if the unused leads from the power transformer are pulled inside the transformer case and securely taped to avoid shorts. This was done with the 2.5 volt and the 5.0 volt windings.

The unit pictured uses a bottom cover plate for the chassis. This is recommended to avoid r-f feed-

back. Any sort of thin metal will serve for this purpose, if your chassis comes without a bottom plate.

Component parts

While no extremely critical values are required, it is recommended that the specified values be used in all cases. For example, C_2 and C_7 are specified as 1.0 mf condensers. If lower values were to be used, the frequency response would suffer, and if higher values were used, the result would be insufficient low-frequency attenuation.

Condenser C_{10} is about the only component which could be changed. Here a 20-20 mf condenser could be used, with one of the 20 μF section on either side of R_{16} .

Almost any sort of push-pull plates to voice coil transformer will serve as T_1 . Wattage rating of this transformer is not important.

If possible, linear taper potentiometers should be used at R_4 and R_{12} . This sort of taper will give a smoother action than other types of taper.

Care must be taken in purchasing the limiter rectifier, W , because instrument rectifiers come in several different styles. Basically, of course, they are used to make a.c. meters out of d.c. meters. However, they can be purchased as half-wave units, doubler units, full-wave units and bridge units.

Two separate half-wave units, connected as shown, will work, and the bridge-rectifier style will work if the proper leads are used. The "full-wave" unit will not serve because the two diode sections are connected improperly. In the doubler type rectifier the two diode units are connected as shown in Figs. 2 and 3 and therefore this type of instrument rectifier would be the best to use.

Compression adjustment

The adjustment of the Logarithmic Compressor is done very easily. Plug in a mike and place the in-out switch, S_2 , in the "out" position so that the microphone is connected directly to your speech amplifier, then follow these three steps:

1. Adjust the audio gain control on the transmitter for normal modulation as seen on an oscilloscope (the best method) or some other instrument worthy of trust.

2. Put the output control on the unit to zero and set the compression control so that it is about half open. Switch the compressor to "in" and advance the output control while speaking into the microphone until the *peak* modulation is the same as

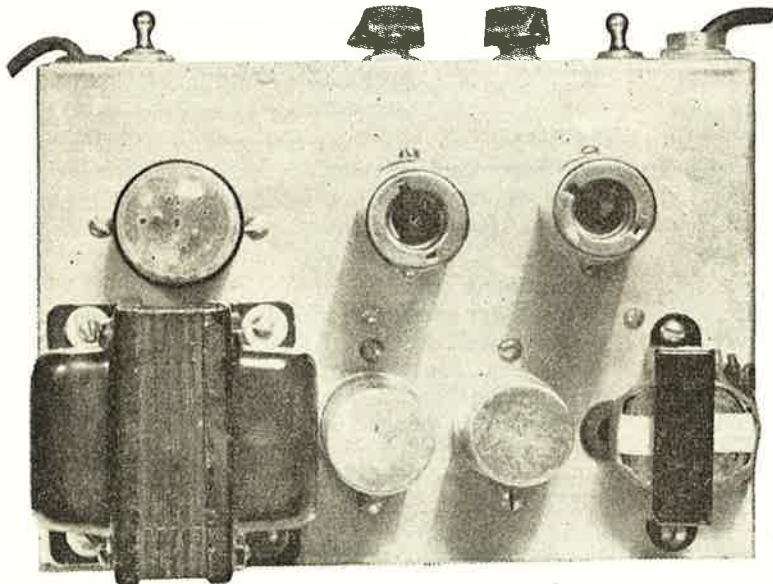

Fig. 5. Top view of the Logarithmic Compressor. The audio section is on the right and the power supply section is on the left.

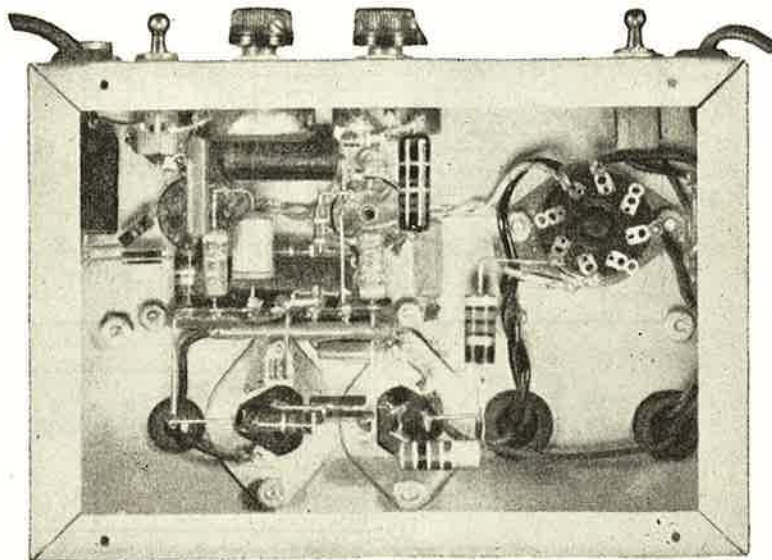

Fig. 4. Under-chassis view of the Logarithmic Compressor. There is ample room for all component parts.

in step 1. While an oscilloscope is not absolutely necessary, in order to make this adjustment, it is strongly recommended.

3. Adjust the compression control so that the average plate current in the modulator stage on a sustained "00000—0" is, say, not over twice that obtained with the compressor out. Then try compressor "in" and "out" on a few QSO's to find the best operating point of the compression control for the microphone you are using and the receiving conditions prevalent at the other fellow's QTH.

Use of the compressor

With the Logarithmic Compressor in use the modulator tubes are required to handle much more average power than usual. In fact, it is possible that your modulator stage will not be capable of handling the extra average power required. Careful checking with an oscilloscope will determine if this is the case.

As a general rule, if your modulator can handle a sine wave signal at 100% modulation, then the average power capability of your modulator is adequate for use with the Logarithmic Compressor. (After all, this ten db gain has to come from some place!) This means that, for a kilowatt rig, your modulator should be capable of continuous operation at 500 watts output at 1000 cycles. For lower powers the same ratio holds.

In operation the compressor must be used with judgment—good judgment that is. Too much compression may make an otherwise acceptable signal almost intolerable. With a judicious amount of compression one can expect to add from 6db

(Continued on page 38)

Selecting a Loudspeaker

HARRY F. OLSON

During the past ten years, improvements from the standpoints of frequency range, lower distortion and noise have been made in the following sound storage and transmitting systems, namely, disc records, magnetic wire and tape and the various broadcasting mediums. These developments have stimulated interest in sound reproducing systems with comparable fidelity. One of the important elements in these high fidelity sound reproducing systems is the loudspeaker. The selection of a loudspeaker for high quality sound reproduction is confusing because emphasis has been placed upon certain factors which are not only unimportant but actually militate against achieving those qualities which are important. It is the purpose of this discussion to indicate the important considerations in the selection of a high quality loudspeaker.

The important characteristics which depict the performance of a loudspeaker are the response frequency, directivity, distortion and transient response. These characteristics are interdependent in any direct radiator loudspeaker. During the past decade considerable emphasis has been placed upon high sensitivity with little regard for the factors of uniform response, broad directivity, low distortion and good transient response.

The reason for this state of affairs is that high sensitivity in a loudspeaker is easily demonstrated and more dramatic than the degradation of quality due to non-uniform response, high distortion and sharp directivity. As a consequence, smooth response, broad directivity, and low distortion have been sacrificed for sensitivity. For example, a loudspeaker with a high order of distortion and a narrow directivity pattern will sound louder than one with low distortion and a broad directivity pattern. However, a careful consideration will show that a more uniform directivity pattern coupled with lower nonlinear distortion at the sacrifice of sensitivity will lead to a superior loudspeaker.

The efficiency of a loudspeaker is a complex function of the flux density, the voice coil mass, the cone mass and cone diameter. With all other factors remaining the same, the efficiency may be increased by decreasing the mass of a cone. Thus it will be seen, by the single expedient of reducing the mass of the cone, the efficiency can be increased and at no increased cost.

A reduction in the mass of the cone decreases the inherent stiffness. For example, a reduction in mass of the cone by one-half decreases the stiff-

ness to one-eighth. A decrease in the stiffness of the cone increases the possibility for the various parts of the cone to break up into different modes of vibration. Under these conditions, the various parts of the cone vibrate with complex and widely different amplitudes and phases. The vibration pattern changes as the frequency is varied. Since the sound output delivered by the cone is the output from all elements, it follows that the sound from the cone will vary with the frequency. In other words, the first consequence of increased sensitivity by a reduction in the mass of the cone is a non-uniform response frequency characteristic.

One of the effects of nonlinearity in the elements of the vibrating system of a loudspeaker is the production of harmonics and subharmonics. Nonlinearity in a cone occurs when the force vs. displacement characteristic deviates from a straight line. As the cone mass and hence the sectional area is decreased, the force at which deviation from a linear characteristic occurs is also decreased. In a light-weight cone, this deviation occurs at a relatively small input. The net result is that as the cone mass is decreased the nonlinear distortion is increased.

The directional characteristic of a loudspeaker is the response as a function of the angle with respect to some reference axis of the system. The directional patterns are usually depicted in polar coordinates. The directivity of a cone radiator can be controlled by the shape and material of the cone. For the same total acoustical output the loudspeaker with a sharp directional pattern will deliver a higher sound pressure on the axis. Since a sharp directivity pattern is undesirable because it leads to wide variations in sensitivity and frequency discriminations for points removed from the axis, the only reason for a sharp directivity pattern is to obtain high sensitivity on the axis.

The transient response characteristics of a loudspeaker depicts the response of the loudspeaker to variations in the amplitude or frequency of the applied signal. Since all speech and music is of a transient nature, the transient response of a loudspeaker is another important performance characteristic of a loudspeaker. Poor transient response in a loudspeaker changes the build up and decay patterns of speech and music. As a result, the reproduced sound is lacking in definition. In general, a loudspeaker with a smooth response frequency characteristic will exhibit a good transient response characteristic.

For home and other small-room sound reproduc-

Reprinted from the Newsletter of the Professional Group on Audio by courtesy of the I.R.E. (U.S.A.).

tion, high sensitivity is not a requirement because the power available from the amplifier is more than adequate to obtain satisfactory sound levels. Even a loudspeaker with moderately low sensitivity will deliver a sound level of 80 db in the average living room for an input of 0.05 watt. Most power amplifiers used in radio receivers are of the order of 5 to 20 watts. Thus it will be seen that a reduction in sensitivity of a few db in the loudspeaker is of no practical significance.

The response frequency, the directivity, the nonlinear distortion and the transient response characteristics can all be measured in the laboratory. These data will depict the performance of the loudspeaker. When these data are not available, considerable information can be obtained from properly conducted listening tests. When loudspeakers are compared in listening tests, the sound outputs should be adjusted to the same level for the following reasons: first, because the shape of the equal loudness contours of the ear varies with the level, and as a result a difference in level will introduce subjective frequency discrimination, and, second, because as developed in the discussion above, sensitivity of a reasonable value is necessary, but great sensitivity is of no significant advantage for home or small scale sound reproduction.

The response frequency characteristic can be checked by the faithfulness of sound reproduction. It is the overtone structure that characterizes a person or a musical instrument. A sound reproducing system with a non-uniform response with respect to frequency alters the relative amplitudes of the

components which constitute the overtone structure of speech and music and makes it impossible to obtain true reproduction.

When a loudspeaker exhibits a high order of nonlinear distortion the result is a production of spurious harmonics or overtones in a reproduced sound. The net effect is to destroy the original overtone structure and thereby render the reproduced speech or music unlike the original. If the nonlinear distortion is high, the reproduction will be fuzzy, raspy and raucous.

The directivity pattern of a loudspeaker can be checked by listening at various angles from the axis and noting the change in over-all level and the frequency discrimination, particularly in the high frequency range.

The transient response can be checked by listening to sound with steep wave fronts, as, for example, wood blocks, castanets, taps, etc. Musical instruments of the struck or plucked string types also exhibit sharp wave fronts and serve as good subjects for transient response determinations. Poor transient response in the low frequency range is usually due to improper cabinet design which leads to a highly resonant system. Poor transient response in the low frequency range is manifested as the same low resonant tone being reproduced regardless of the low frequency input.

To summarize, the foregoing discussion has shown that in the selection of a loudspeaker, it is undesirable to obtain high sensitivity by sacrificing uniform frequency response, good transient response, low nonlinear distortion and broad and uniform directivity.

LOGARITHMIC COMPRESSOR *(Continued from page 36)*

(4 to 1 in power) to 10 db (10 to 1 in power) in the effectiveness of his signal *provided* conditions at the receiving point are such that understandability without the compressor is impaired by QRM or high background noise.

Results with the compressor

In many months of test at W2KUJ the following information has been obtained. Nearby stations, or stations not experiencing QRM, prefer that the compressor *not be* used. Stations receiving a weak signal or listening through severe QRM prefer that the compressor *be* used.

Reports from the latter stations range from eight to ten db jump in effective signal strength when the compressor is switched in. Reports from nearby stations are that the signal is *louder*, but somewhat less readable with the compressor in use than without it.

In no case has a report been given that the signal was broader when the compressor was used, even when this question was asked of nearby stations.

Tests made at W2RYT's shack indicate that different microphones give somewhat different results when used with the compressor. For example, an Electro-Voice Model 605 dynamic mike (pictured in Fig. 1) and an Electro-Voice Model 915 crystal

mike seemed to have identical speech characteristics (although the dynamic mike had less output) when used without the compressor.

When used with the compressor, the dynamic mike was found to have a speech quality which was less harsh than that of the crystal mike. Further, it was found advisable to advance the compression control with the dynamic mike.

The foregoing is not intended as a recommendation for dynamic mikes, nor is it intended as an authoritative comparison between two Electro-Voice microphones. The comparison has been made to emphasize the importance of testing your compressor carefully with each microphone you may use with it.

In summary, one can expect to boost the effectiveness of his signal when it is needed most by use of the compressor (it frequently means the difference between making a contact or not) with some decrease in ease of reading the signal where the compressor is not needed.

Bear in mind that the compressor *can be* misused (to your disadvantage). Seek honestly to find the operating points which best exploit its use. In many cases it is best to *not* use the compressor. But in those cases where it is needed, the Logarithmic Compressor can really do a job for you.

RADIOTRON CLASSIFIED EQUIPMENT VALVE TYPES

RADIOTRON LIST OF EQUIPMENT TYPES

JANUARY, 1952

This list of types is presented to assist equipment manufacturers in planning for future production of broadcast receivers and similar equipment.

By using types shown on this list in bold face, manufacturers will tend to reap the benefits of better availability, lower cost and better quality.

These types are in general made in Australia, and are intended to satisfy the main requirements of receiver manufacturers.

To extend the advantage of standardisation to valves for miscellaneous applications, a number of other types are included on the list, and these are shown in ordinary type. A list of specific T.V. types is not given, as developments in this field are at present so rapid. Advice on the best choice of T.V. types will be given on enquiry.

CLASSIFICATIONS	Current Receiver Equipment Types						Additional Types for Miscell. Application	
	Battery		A.C.		A.C./D.C.		Miniature	Octal
	Miniature	Octal	Miniature	Octal	Miniature	Octal		
Frequency Converters	1R5	1C7-G	6BE6	6A8-G	12BE6			
			6AE8	X61M				
R-F Pentodes. Remote Cut-Off	1T4	1M5-G	6BA6	6U7-G	12BA6			
R-F & A-F Pentodes. Sharp Cut-Off		1K5-G	6AU6		12AU6	Z77	6J7-G/1620	
Double-Diode R-F Pentodes		1K7-G		6AR7-GT 6B8-GT				
Diode A-F Pentodes	1S5							
Double-Diode Triodes			6AV6	6SQ7-GT	12AT6			
Double-Diodes						6AL5		
Double-Triodes						12AT7 12AU7 12AX7 6J6	6SN7-GT	
Triodes						6C4		
Output Tetodes & Pentodes	3S4 3V4	1L5-G	6AQ5 6BJ5	6V6-GT	50C5		KT66	
Half-Wave Rectifiers					35W4			
Full-Wave Rectifiers			6X4	5Y3-GT 6X5-GT			U52/5U4-G	

N.B.—Recommended types are shown in bold face.

Radiotron Type 6080

RCA-6080 is a low- μ , high-perveance, twin power triode of the heater-cathode type intended for use as a regulator tube in dc power supply units, and in projection television booster scanning applications where pulsed plate voltages of high value are encountered.



Having conservative ratings, the 6080 employs a compact design in which special attention has been given to features which improve its strength both as to shock and vibration. This type utilizes a button stem which strengthens the mount structure and provides relatively wide inter-lead spacing. Because of this spacing between leads, susceptibility to electrolysis is reduced. These features all contribute to the dependability of the 6080.

These features all contribute to the dependability of the 6080.

SOCKET CONNECTIONS Bottom View

- PIN 1: GRID OF UNIT No. 2
- PIN 2: PLATE OF UNIT No. 2
- PIN 3: CATHODE OF UNIT No. 2
- PIN 4: GRID OF UNIT No. 1
- PIN 5: PLATE OF UNIT No. 1
- PIN 6: CATHODE OF UNIT No. 1
- PIN 7: HEATER
- PIN 8: HEATER

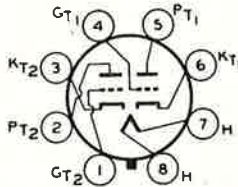

GENERAL DATA

Heater, for unipotential cathodes:		
Voltage (AC or DC)	6.3 $\pm 10\%$	volts
Current at 6.3 volts	2.5	amp
Direct Interelectrode Capacitances (Each Unit, without external shield)		
Grid to Plate	8.4	$\mu\mu\text{f}$
Input	6.2	$\mu\mu\text{f}$
Output	2.2	$\mu\mu\text{f}$
Heater to Cathode:		
Triode Unit No. 1	6.5	$\mu\mu\text{f}$
Triode Unit No. 2	6.1	$\mu\mu\text{f}$
Grid of Unit No. 1 to Grid of Unit No. 2	0.50	$\mu\mu\text{f}$
Plate of Unit No. 1 to Plate of Unit No. 2	2.20	$\mu\mu\text{f}$

Values are for Each Unit

Maximum Ratings, Absolute Values:

PLATE VOLTAGE	250 max.	volts
PLATE CURRENT	125 max.	ma
PLATE DISSIPATION	13 max.	watts
PEAK HEATER-CATHODE VOLTAGE:		
Heater negative with respect to cathode	300 max.	volts
Heater positive with respect to cathode	300 max.	volts
BULB TEMPERATURE [Ⓞ]	200 max.	$^{\circ}\text{C}$

Maximum Circuit Values:

Grid-Circuit Resistance:		
For cathode-bias operation	1.0 max.	megohm
For fixed-bias operation [Ⓚ]	0.1 max.	megohm
For combined fixed- and cathode-bias operation [Ⓚ]	0.1 max.	megohm

Characteristics (Each Unit):

Plate-Supply Voltage	135	volts
Cathode-Bias Resistor	250	ohms
Amplification Factor	2	
Transconductance	280	ohms
Plate Current	7000	μmhos
	125	ma

Mechanical:

Mounting Position	Any
Maximum Overall Length	4-1/4"
Maximum Seated Length	3-11/16"
Maximum Diameter	1-23/32"
Bulb	T-12
Base	Short Jumbo-Shell Octal B-Pin (JETEC No. BB-71)

Ⓚ when fixed bias is used, the plate circuit should contain a protective resistance to provide a minimum drop of 15 volts dc at the normal operating conditions.

Ⓚ when combined fixed- and cathode-bias is used, the cathode-bias portion should have a minimum value of 7.5 volts dc at the normal operating conditions.

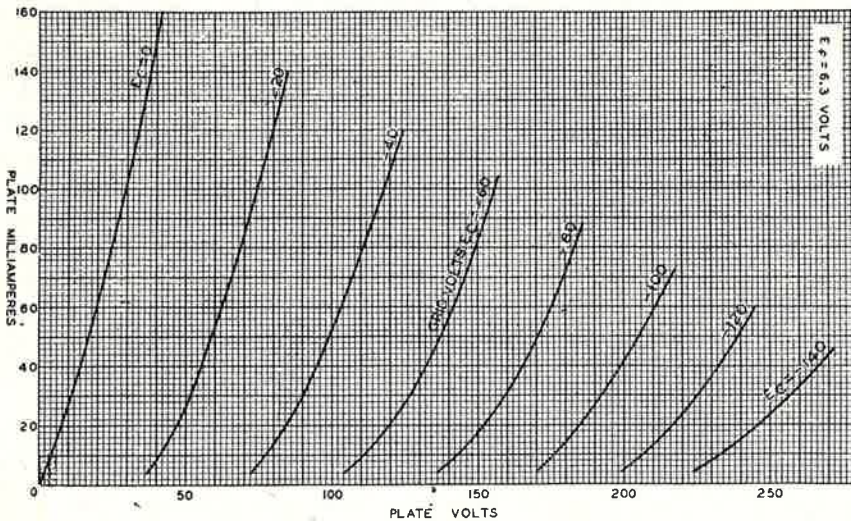

Average Plate Characteristics
For Each Triode Unit
of Type 6080.