

R.F. PENTODE WITH VARIABLE MUTUAL CONDUCTANCE

The new variable- μ R.F. pentode DF 97 is specially designed for use in AM/FM sets as an I.F. amplifier, as a self oscillating additive frequency changer for the FM range and as a multiplicative mixer tube for the AM range.

The DF 97 has a 7-pin miniature base and requires a filament current of 25 mA similar to the tubes of the D 96 series.

When used as an I.F. amplifier at 10.7 Mc/s the DF 97 supplies a higher gain than the DK 96, due to its higher mutual conductance and smaller anode-to-grid capacitance.

The third grid base has been kept small so that the conversion conductance of the DF 97 when serving as a multiplicative mixer tube at AM reception is $280 \mu\text{A/V}$ at an oscillator voltage of $12 V_{\text{rms}}$.

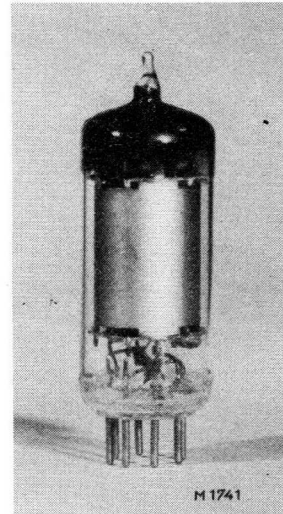

Fig.1.

If the DF 97 is used as a self oscillating frequency changer for FM reception it is connected as a triode with its screen grid and suppressor grid linked to the anode. By using the DF 97 in AM/FM sets it is no longer necessary to use the DK 96 as a frequency changer tube for AM reception. The conversion gain of the DF 97 used as a multiplicative mixer tube for AM reception is roughly the same as that of the DK 96.

THE DF 97 AS AN I.F. AMPLIFIER IN AM/FM SETS

Due to its higher mutual conductance the DF 97 supplies a higher gain at FM reception than the DF 96; at AM reception both tubes are equivalent. With an AM bandpass filter having circuit impedances of, for example, $220 \text{ k}\Omega$ a gain of 76.5 can be obtained with the DF 96 ($S = 850 \mu\text{A/V}$; $R_i = 1 \text{ M}\Omega$), whereas with the DF 97 ($S = 920 \mu\text{A/V}$; $R_i = 0.42 \text{ M}\Omega$) a gain of 74 can be achieved. Compared with the DF 96, the higher mutual conductance of the DF 97 roughly compensates for the difference in trans-resistance due to the smaller R_i of the DF 97.

The quoted screen grid resistor of $4.7 \text{ k}\Omega$ for a supply voltage of 64 V can be omitted if this voltage is only 60 V.

Fig.2 represents a block diagram of a seven tubes AM/FM battery mains receiver with four 10.7 Mc/s I.F. stages. The first tube DF 97, which

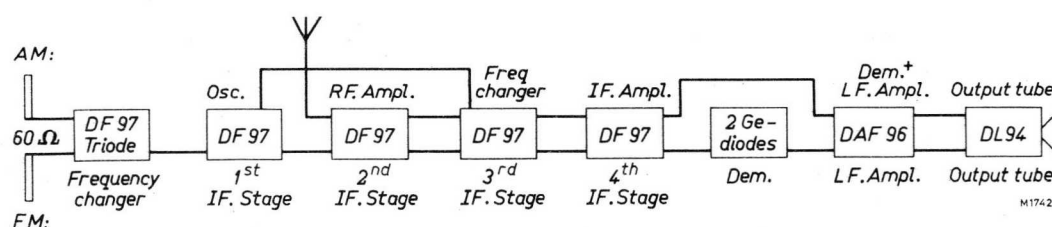

Fig.2.

operates as a self oscillating frequency changer at FM reception has no function here at AM reception; this offers the advantage that switching becomes superfluous. The great reserve of gain offered by the presence of four I.F. stages can advantageously be used for obtaining a sharp limiting in the discriminator. With an input voltage at the discriminator of $4 V_{rms}$ a sensitivity of approx. $1.5 \mu V$ can be obtained at the terminals of a 60Ω antenna, at an AF bandwidth of 15 kc/s and a signal-to-noise ratio of 26 dB.

At AM reception an input sensitivity of $6 \mu V$ can be obtained at the terminals of the antenna with an A.F. voltage of 28 mV at the control grid of the DAF 96. In this case an aperiodic R.F. stage is supposed to precede the DF 97 mixer stage. When the DF 97 operates as an I.F. amplifier for 10.7 Mc/s it has considerably better properties than the DK 96. With a static mutual conductance of $920 \mu A/V$ and a transresistance of $20 k\Omega$ an I.F. gain of about 18 can be obtained: $G_{IF} = S \cdot R_{tr} = 0.92 \cdot 20 = 18$, assuming a circuit with single C_{ag} neutralisation being used, as indicated in Fig.3.

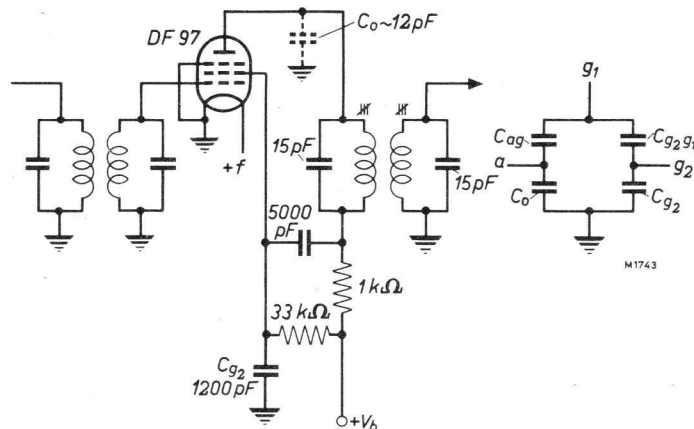

Fig.3.

C_{g2} is a decoupling capacitor of 1200 pF. The effective value of this capacitor at 10.7 Mc/s is, however, considerably higher due to the inductance of the supply leads. The principle of operation of the neutralising circuit is also indicated in Fig.3. It is seen that a bridge is formed, by which the influence of C_{ag} is eliminated.

A gain of only 6 can be obtained with the DK 96 at 10.7 Mc/s and therefore in AM/FM battery sets the DF 97 will be preferred, whereas in pure AM sets the DK 96 will give better results, on account of the fact that an additional oscillator tube would have to be used in that case with the DF 97.

THE DF 97 AS AN ADDITIVE FREQUENCY CHANGER FOR FM RECEPTION

The high conversion conductance of the DF 97, which may amount to $500 \mu A/V$, renders this tube equivalent to the DC 90 when used as an additive frequency changer at FM reception; the filament current of the former tube is, however, half that of the DC 90. Moreover, the DF 97 offers the advantage of a considerably lower oscillator voltage being required, so that radiation of the oscillator can easily be kept small.

When comparing tubes, care must be taken to consider comparable oscillator ratings, viz. the ratio of the oscillator voltage at the operating point to the oscillator voltage at the top of the conversion gain curve must be the same for both tubes. For battery tubes the best ratio in this respect is:

$$V_{osc}/V_{osc} \text{ at } S_c \text{ max} = 1.25 \text{ to } 1.3.$$

The corresponding values at a supply voltage of 64 V are: $S_c = 280 \mu\text{A/V}$ and $R_i = 0.3 \text{ M}\Omega$. If a multiplicative mixer stage containing the DF 97 is to be controlled at short wave reception transit time effects give rise to a current flowing to the first grid of the tube; this current depends on the frequency and the amplitude of the oscillator voltage at the third grid. (In principle, the same phenomena will also occur with frequency changer hexodes.)

This current supplies a negative bias to all tubes incorporated in the A.G.C. circuit the diode-detector included. The lower the screen grid voltage, the more negative the control grid and the more positive the suppressor grid is, the smaller this bias will be. This implies that at short wave reception with A.G.C. the screen grid resistor should not be chosen lower than 47 k Ω ; this value is also quoted in the data for 85 V. Moreover, the grid of the oscillator tube should be coupled capacitively to the grid of the mixer tube to prevent the negative bias of the oscillator tube being supplied to the DF 97. By this capacitive coupling it is also avoided that the conversion conductance is decreased due to a negative grid bias of g_3 .

The oscillator frequency must be higher than the signal frequency. The influence of the control grid current on the gain then depends exclusively on the circuitry of the A.G.C. and detector circuits.

At short wave reception with a controlled DF 97 mixer stage and parallel supply the total sensitivity can be improved by connecting the load resistor of the detector to the positive supply lead instead of to the negative lead.

The negative voltage arising across the grid leak resistor of DF 97 mixer tube due to the control grid current is applied to a voltage divider in the A.G.C. circuit and subsequently fed to the detector diode. Fig.5 shows the A.G.C. circuit at parallel supply. In this circuit $R_{g_1 \text{ tot}}$ is 3 M Ω and the voltage dividing ratio is 3:1. This ratio becomes 5:1 at a diode resistor of 0.5 M Ω instead of 1 M Ω . An excessive bias would then be applied to the detector if its load resistor were connected to the negative lead, and the rectifying action of the detector would decrease considerably. By connecting the detector to the positive lead however, the operating point remains within a favourable range as regards the total sensitivity.

The influence on the other tubes of the additional bias at the detector due to the control grid current of the DF 97 mixer tube remains small, provided the A.G.C. voltage for these tubes is taken directly from the load resistor of the detector as shown in Fig.5 for the DF 97 I.F. ampli-

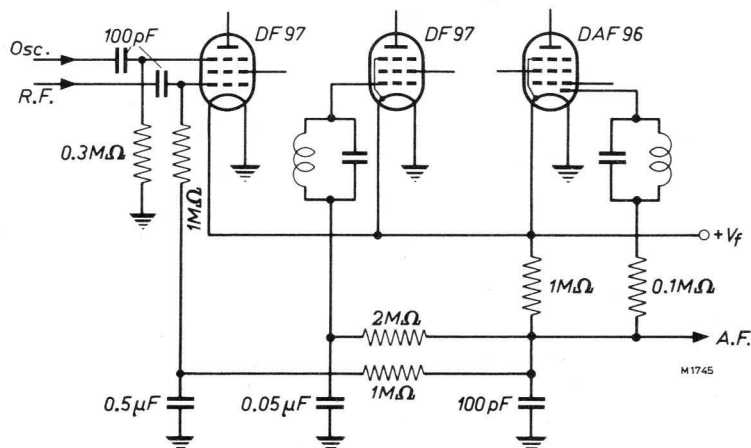

Fig.5.

fier tube. This is due to the fact that the curve $S = f(V_g)$ is almost horizontal in the vicinity of the point at which V_g is zero. The A.G.C. circuit at series supply is somewhat more complicated owing to the required correct adjustment of the biases; it can, however, also be designed in such a way that the grid current of the DF 97 mixer tube does not give rise to any inconvenience (see Fig.6).

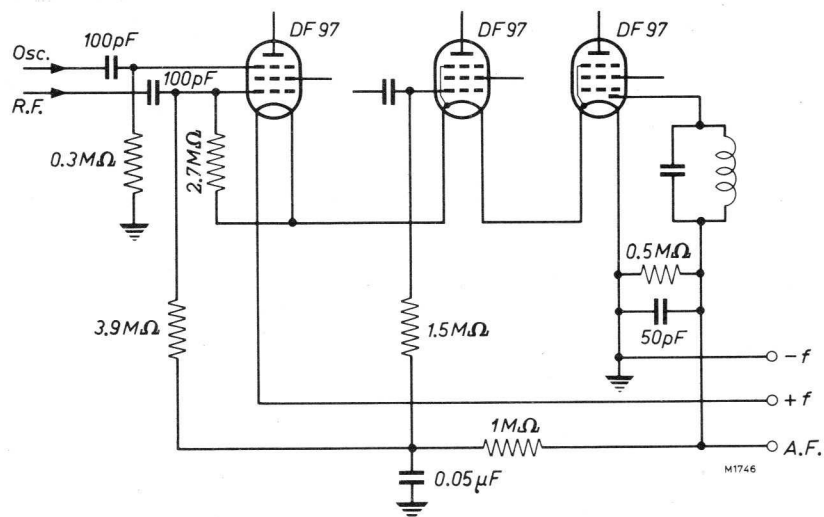

Fig. 6.

At series supply the tubes with a high filament potential are generally provided with a grid leak resistor connected to the negative filament supply lead in order to obtain a sufficiently high gain.

The possibility of controlling the tubes is, however, limited in this way. To obtain adequate control of the DF 97 I.F. stage that follows the detector in the supply chain, its grid leak resistor is usually omitted, although the gain is slightly reduced thereby. In Fig.6 the positive cathode voltage is supplied to the A.G.C. circuit through the 2.7 MΩ grid leak resistor of the DF 97 mixer tube. In this way the current flowing from the control grid of this tube to the A.G.C. circuit is partly compensated for. The ultimate grid bias at the control grid of the DF 97 mixer tube is divided into the ratio 10:1 by the resistors in the A.G.C. circuit and then applied to the detector diode of the DAF 96. The influence of the control grid current of the DF 97 is thus minimised and as regards the total sensitivity it is practically the same whether the load resistor of the detector is connected to the positive or to the negative supply lead. In Fig.6 it is connected to the negative lead.

As a consequence of the additional grid bias arising in the A.G.C. circuit being so small, the control grid to the DF 97 I.F. amplifier tube may be connected at any point to the A.G.C. circuit.

With the circuits of the Figs 5 and 6 the gain at short-wave reception hardly decreases by incorporating the DF 97 mixer stage in the A.G.C. circuit and the damping due to the control grid current of the DF 97 is negligible. In a multiplicative mixer stage provided with the DF 97 A.G.C. may be applied without objection up to 20 Mc/s.

If in circuits designed with the DF 97 no A.G.C. is applied at short-wave reception, there is obviously no need to take the control grid current of the tube into account.

To generate the necessary oscillator voltage at g_3 , one of the tubes that have no function at AM reception can be connected as an oscillator. This may be either a DF 97 serving as an I.F. amplifier at FM reception or a DF 97 serving as a self oscillating frequency changer at FM reception.

TECHNICAL DATA

HEATING: direct by d.c.

series or parallel supply.

Parallel supply: $V_f = 1.4 \text{ V}$

$I_f = 25 \text{ mA}$

Series supply: $V_f = 1.3 \text{ V}$

$I_f = 24 \text{ mA}$

Dimensions in mm

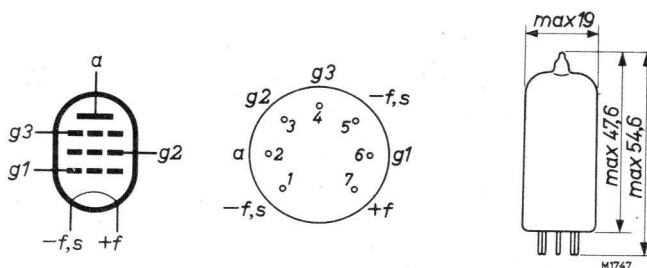

Fig. 7.

DIRECT INTERELECTRODE CAPACITANCES: (triode connection)¹⁾

Anode to all other elements

$$C_a = 8.1 \text{ pF}$$

Grid to all other elements

$$C_g = 1.1 \text{ pF}$$

Anode to grid

$$C_{ag} = 2.6 \text{ pF}$$

DIRECT INTERELECTRODE CAPACITANCES: (pentode connection)

Anode to all other elements

$$C_a = 7.5 \text{ pF}$$

Grid No.1 to all other elements

$$C_{g_1} = 3.7 \text{ pF}$$

Grid No.3 to all other elements

$$C_{g_3} = 5.2 \text{ pF}$$

Anode to grid No.1

$$C_{ag_1} < 0.01 \text{ pF}$$

Grid No.1 to grid No.3

$$C_{g_1 g_3} < 0.1 \text{ pF}$$

Grid No.1 to grid No.2

$$C_{g_1 g_2} = 2.5 \text{ pF}$$

OPERATING CHARACTERISTICS AS I.F. AMPLIFIER

Anode voltage (battery voltage) ²⁾	85	64	V
Grid No.3 voltage	0	0	V
Grid No.2 series resistance	33	4.7	kΩ
Grid No.1 voltage	0	-5	-3.8 V
Grid No.2 voltage	61	85	- V
Anode current	1.75	-	1.68 - mA
Grid No.2 current	730	-	770 - μA
Mutual conductance	920	10	840 10 μA/V
Internal resistance	0.42	>10	0.27 >10 MΩ
Amplification factor of grid No.2 with respect to grid No.1	18	-	18 -

¹⁾ g_2 and g_3 connected to anode.

²⁾ Based on an H.T. battery voltage of 90 or 67,5 V respectively minus the bias of the output tube; voltage with respect to -f.

OPERATING CHARACTERISTICS AS MIXING TUBE WITH OSCILLATOR VOLTAGE ON g_3 ²⁾

Anode voltage (battery voltage) ¹⁾	85		64	V
Grid No.2 series resistance	47		4.7	k Ω
Oscillator voltage	12		12	V _{eff}
Grid No.3 series resistance	300		300	k Ω
Grid No.1 voltage	0	-4.6	0	-3.5 V
Grid No.2 voltage	45	85	58	64 V
Anode current	565	-	730	- μ A
Grid No.2 current	840	-	1370	- μ A
Conversion conductance	265	10	280	10 μ A/V
Internal resistance	0.50	>5	0.30	>5 M Ω

OPERATING CHARACTERISTICS AS SELF-OSCILLATING FREQUENCY CHANGER:

(triode connection, g_2 and g_3 connected to anode)

Battery voltage	64	64	85	85 V
Bypassed anode resistor	3.3	0	4.7	0 k Ω
Grid series resistance	1	1	1	1 M Ω
Grid current	2.5	3.1	3.8	4.4 μ A
Anode current	1.25	1.35	1.75	2.1 mA
Conversion conductance	460	475	490	500 μ A/V
Oscillator voltage	2.5	3.0	3.5	4.0 V _{eff}
Internal resistance	28.5	29	27	27 k Ω

LIMITING VALUES

Battery voltage	max.	120 V
Battery voltage, absolute limit	max.	150 V
Anode voltage	max.	120 V
Anode dissipation	max.	0.25 W
Grid No.2 voltage	max.	90 V
Grid No.2 dissipation	max.	0.15 W
Cathode current	max.	2.5 mA
Grid No.1 series resistance	max.	3 M Ω
Grid No.3 series resistance	max.	300 k Ω
Positive grid No.1 voltage at grid No.1 current is +0.3 μ A	min.	0 V

¹⁾ Based on an H.T. battery voltage of 90 or 67.5 V respectively minus the Bias of the output tube; voltage with respect to -f.

²⁾ If in the short wave range A.G.C. is applied to the mixing tube, the current flowing to g_1 due to transit time effect should be taken into account.

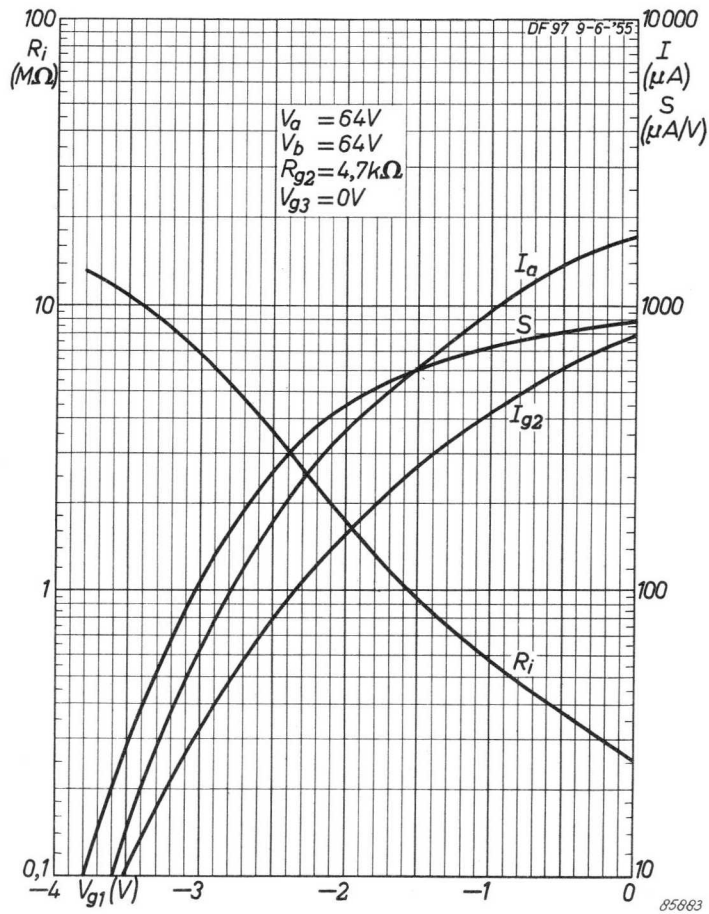

Fig.8. Anode current (I_a), screen grid current (I_{g2}), mutual conductance (S), internal resistance (R_i) as functions of the control grid voltage V_{g1} , at an anode voltage of 64 V.

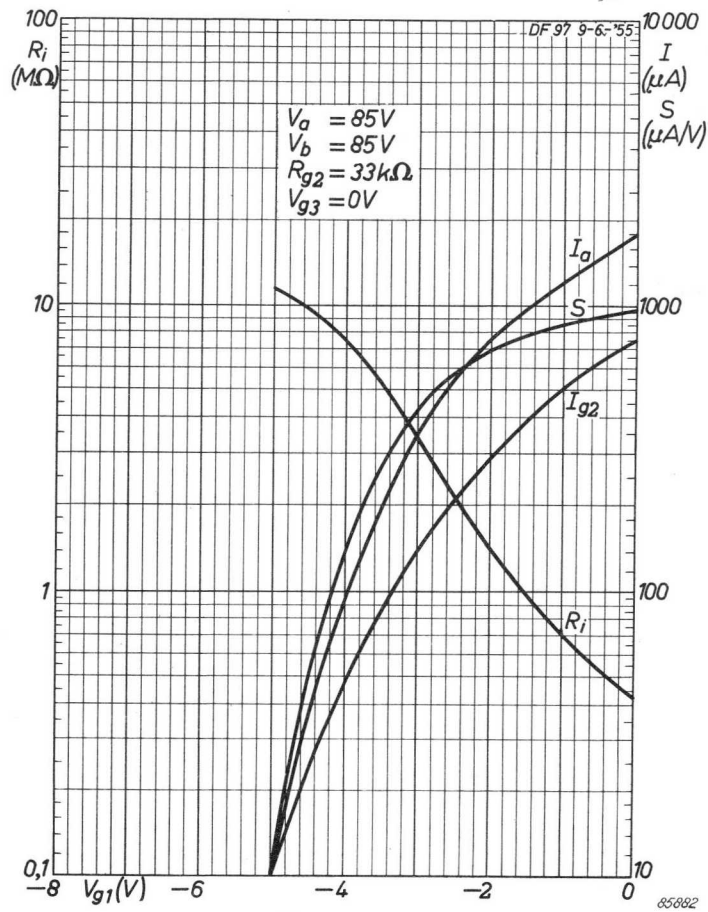

Fig.9. Anode current (I_a), screen grid current (I_{g2}), mutual conductance (S), internal resistance (R_i) as functions of the control grid voltage V_{g1} , at an anode voltage of 85 V.

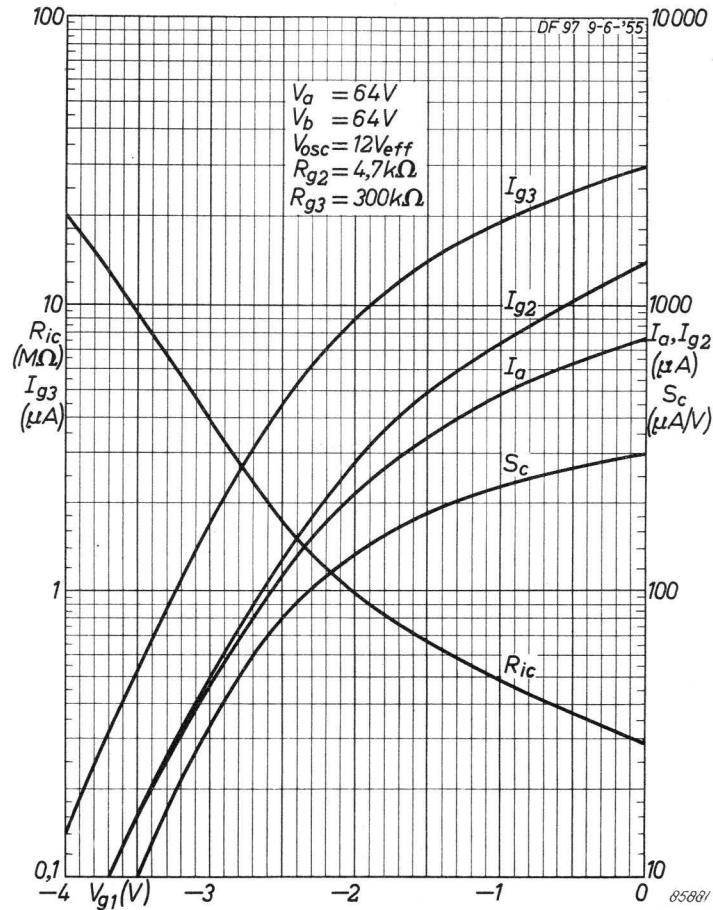

Fig.10. Anode current (I_a), screen grid current (I_{g2}), suppressor grid current (I_{g3}), conversion conductance (S_c), internal resistance (R_{ic}) as functions of the control grid voltage V_{g1} , at an anode voltage of 64 V and an oscillator voltage of 12 V_{eff} . Tube used as a multiplicative mixing tube.

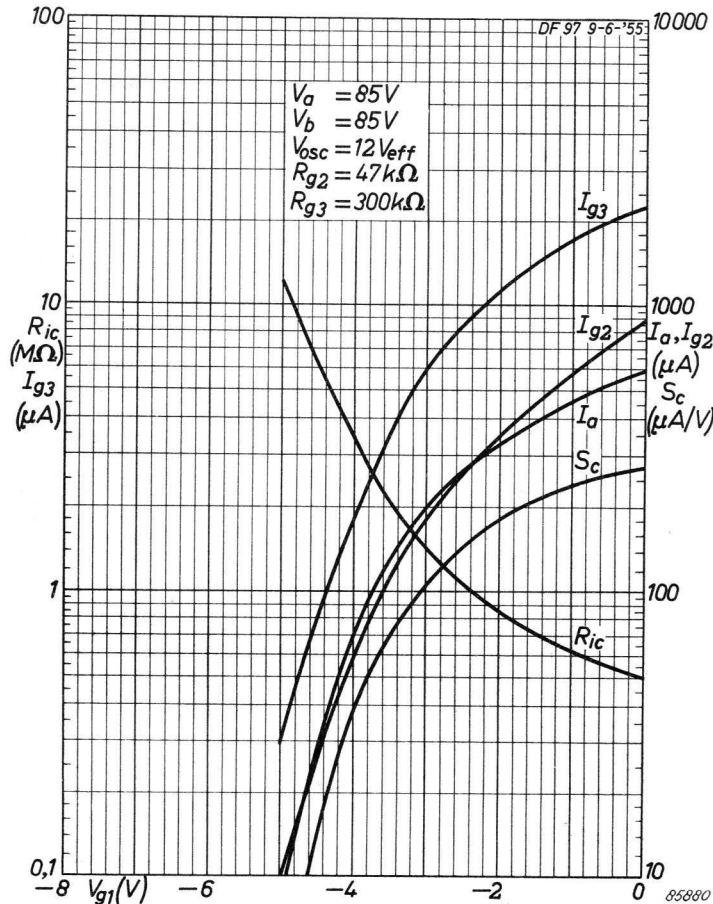

Fig.11. Anode current (I_a), screen grid current (I_{g2}), suppressor grid current (I_{g3}), conversion conductance (S_c), internal resistance (R_{ic}) as functions of the control grid voltage V_{g1} , at an anode voltage of 85 V and an oscillator voltage of 12 V_{eff} . Tube used as a multiplicative mixing tube.

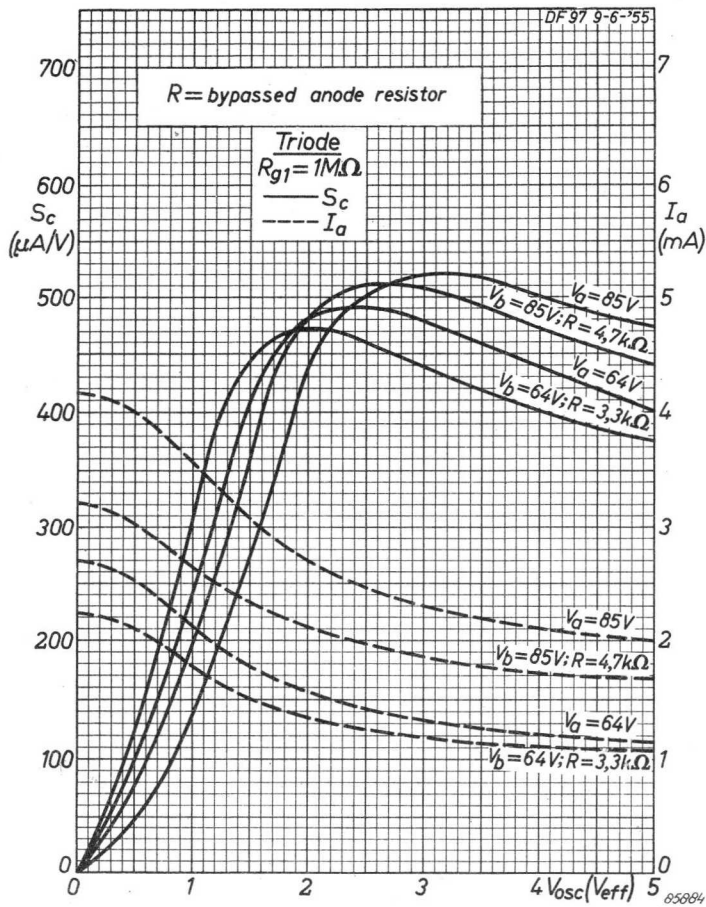

Fig.12. Anode current (I_a) and conversion conductance (S_c) as functions of the oscillator voltage V_{osc} (V_{eff}) at different values of the anode voltage V_a and the bypassed anode-resistor R . Tube used as a self oscillating frequency changer in triode connection.

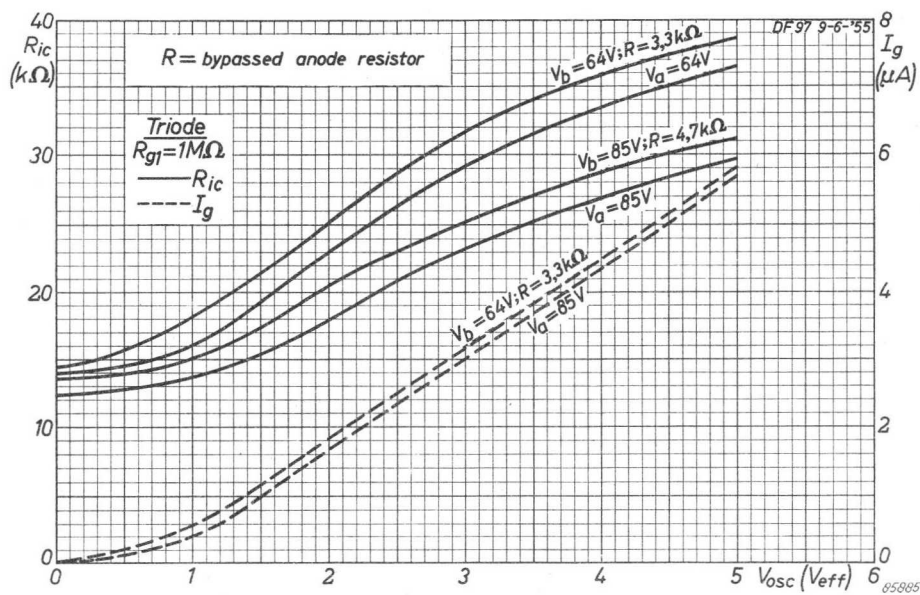

Fig.13. Grid current (I_g) and internal resistance (R_i) as functions of the oscillator voltage V_{osc} (V_{eff}) at different values of the anode voltage V_a and the bypassed anode resistor R . Tube used as a self oscillating frequency changer in triode connection.

The information given in this Bulletin does not imply a licence under any patent.

0,25 €